

Guide
TO THE
REGULATION RESPECTING
SPECIAL PERMITS

Provisional edition
December 1993

Handwritten text along the right edge of the page, possibly bleed-through from the reverse side. The text is vertically oriented and appears to be a list or series of entries, though the characters are difficult to decipher due to the image quality and orientation.



*Guide
TO THE
REGULATION RESPECTING
SPECIAL PERMITS*

*Provisional edition
December 1993*

Legal deposit
Bibliothèque nationale du Québec
ISBN : 2-550-36978-5

INTRODUCTION

This guide contains the main provisions of the Regulation respecting special permits (O.C. 1444-90, 3 October 1990), which came into force in November 1990, and of the Regulation to amend the Regulation respecting special permits (O.C. 1605-93, 17 November 1993), which came into force on January 24, 1994.

The changes and additions made by the Regulation to amend the Regulation respecting special permits appear in **bold** and *italic*, and are integrated into the text of the Regulation respecting special permits.

NOTICE

This guide is provided for information only.

For a legal interpretation, please consult the official texts.

TABLE ON CONTENTS

CHAPTER 0.1	
Interpretation	6
CHAPTER I	
Categories	10
Class 1	11
Class 2	14
Class 3	16
Class 4	17
Class 5	18
Class 6	20
Class 7	21
CHAPTER II	
Conditions for issue, form and content of a permit	22
CHAPTER III	
Conditions attached to permits	28
CHAPTER IV	
Division I - Warning signals	34
Division II - Traffic rules	48
CHAPTER V	
Fees exigible for a special permit	55
CHAPTER VI	
Offences	59
CHAPTER VII	
Transitional and final	59

SCHEDULE 1

Division 1 - Determination of the maximum axle load	60
Division 2 - Determination of the total loaded mass (GVW)	62
Division 3 - Thaw	74

SCHEDULE 2

Board «D» (Sign)	76
------------------------	----

SCHEDULE 3

Additional conditions	77
-----------------------------	----

SCHEDULE 4

Network of autoroutes	81
-----------------------------	----

SCHEDULE 5

Board (Convoi de véhicules hors normes) (Sign for convoy of oversized vehicles)	84
--	----

SCHEDULE 6

Board (Sur les ponts ce véhicule doit circuler à vitesse réduite seul et au centre) (Sign for special conditions relating to travel on bridges)	85
--	----

SCHEDULES 7 TO 11

Signalling for an oversized vehicle on a bridge	86
---	----

SCHEDULE 12

Method for using signal arrow lights on front and rear escort vehicles on a road with only one traffic lane in the direction travelled by the oversized vehicle	91
--	----

Method for using signal arrow lights on a rear escort vehicle on a road with 2 or more traffic lanes in the direction travelled by the oversized vehicle	92
---	----

CHAPTER 0.1
INTERPRETATION

0.1 For the purposes of this Regulation:

- "tandem axle"* : means a combination of 2 axles attached to a vehicle by a suspension system designed to distribute equally at all times, within a margin of 1 000 kg, the mass that can be measured under the wheels of each axle and consisting of a single shared suspension or of 2 identical suspensions attached together;
- "triple axle"* : means a combination of 3 equally spaced axles attached to a vehicle by a suspension system designed to distribute equally at all times, within a margin of 1 000 kg, the mass that can be measured under the wheels of each axle and consisting of 3 identical suspensions attached together;
- "quadruple axle"* : means a combination of 4 axles attached to a vehicle by a suspension system designed to distribute equally at all times, within a margin of 1 000 kg, the mass that can be measured under the wheels of each axle and consisting of 4 identical suspensions attached together.

ILLUSTRATIONS OF TANDEM, TRIPLE AND QUADRUPLE AXLES
THAT COMPLY WITH THE DEFINITIONS

Tandem axles

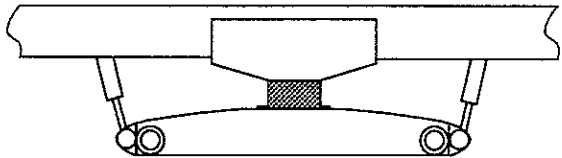
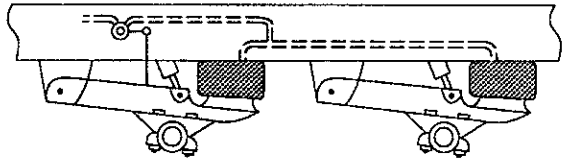
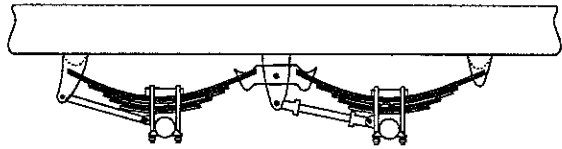

Triple axles

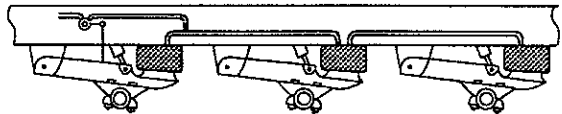

Quadruple axles

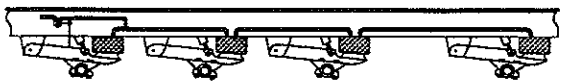
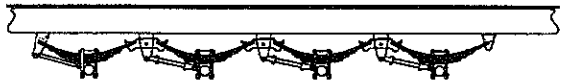

"crane" : *means a lifting device installed on a road vehicle having no fifth wheel and no loading space other than that designed for the attachments of that lifting device;*

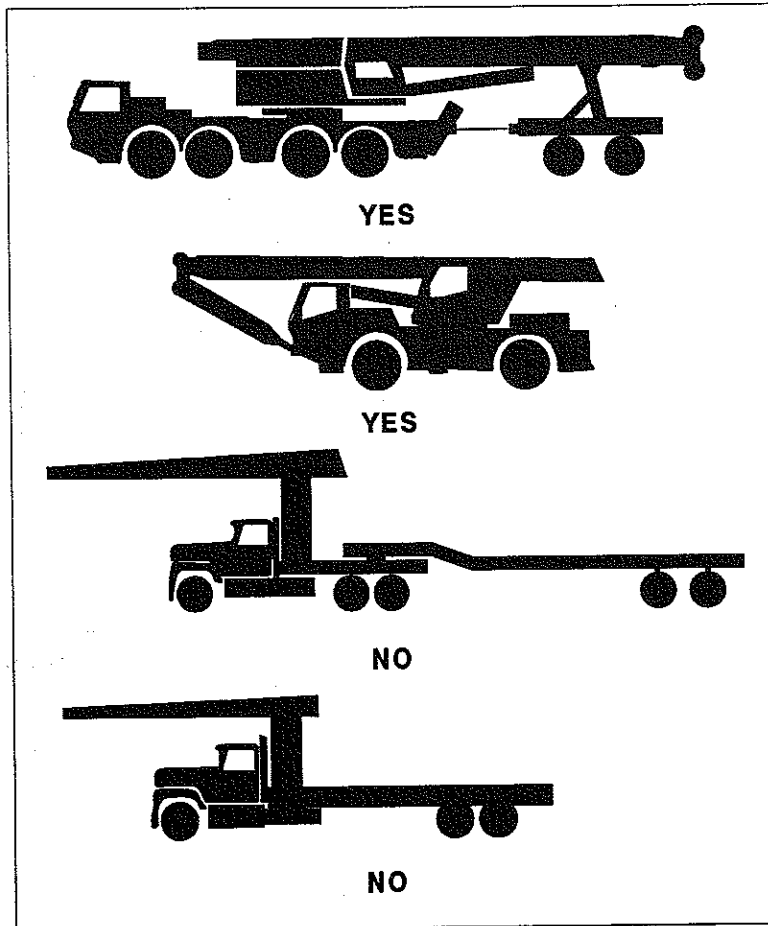

"bridge" : *means a bridge or viaduct.*

0.2 *Unless otherwise indicated by the context, the dimensions given for width in this Regulation do not include rear-view mirrors, provided that such mirrors do not extend beyond each side of the oversized vehicle by more than 250 mm, nor lights and coupling devices, provided that they do not extend beyond each side of the oversized vehicle by more than 100 mm.*

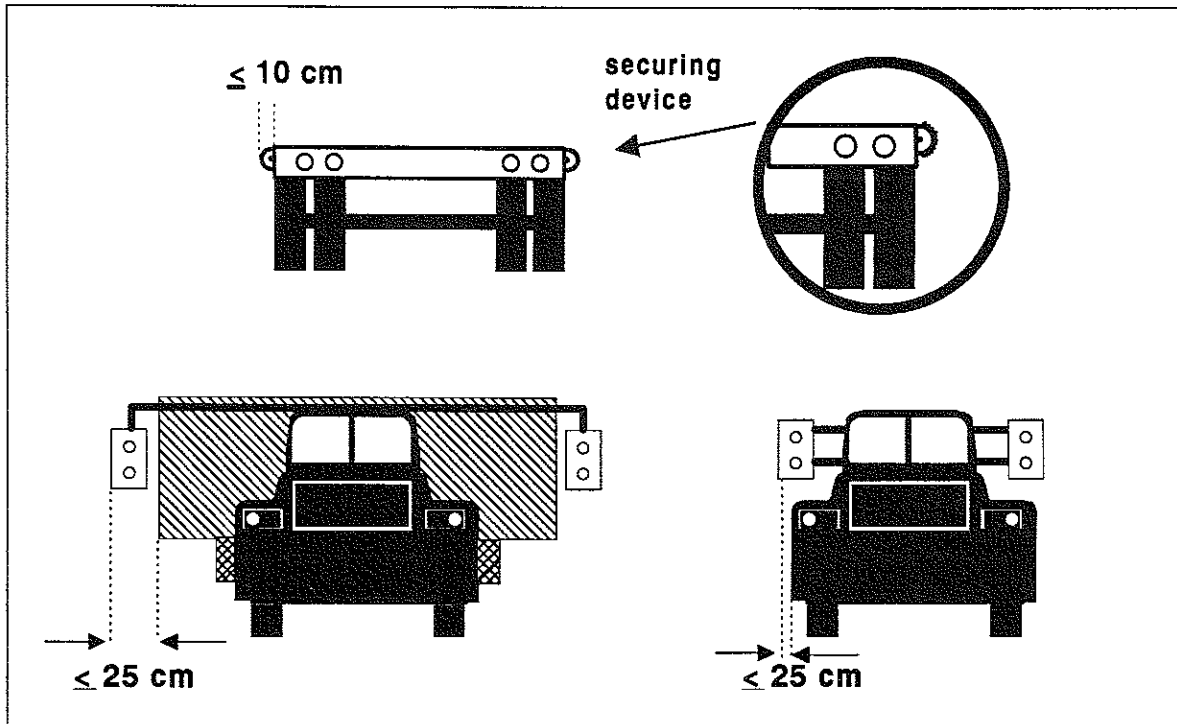

CHAPTER I
CATEGORIES AND CLASSES

1. A special travel permit belongs to one of the following categories:
 - (1) a general permit that authorizes its holder to make trips with or without a specified route for not longer than one year;
 - (2) a specific permit that authorizes its holder to make a trip with a specified route, *including the return trip along the same route*, for not longer than 7 consecutive days.

CATEGORIES		
	GENERAL	SPECIFIC
PERIOD	From one month to a maximum of one year	Maximum of 7 consecutive days
ROUTE	Specified route All public roads The network of autoroutes as described in Schedule 4	Specified route
NUMBER OF TRIPS	Multiple	Single trip: outward journey, return journey or round trip

2. The general permit and specific permit belong to one or more of the following classes:

(1) Class 1:

a permit authorizing the following limits including the load and equipment, including a vehicle that was manufactured as an oversized vehicle, but without a divisible load:

(a) width: 4.40 m or 5 m in the case of a specific permit;

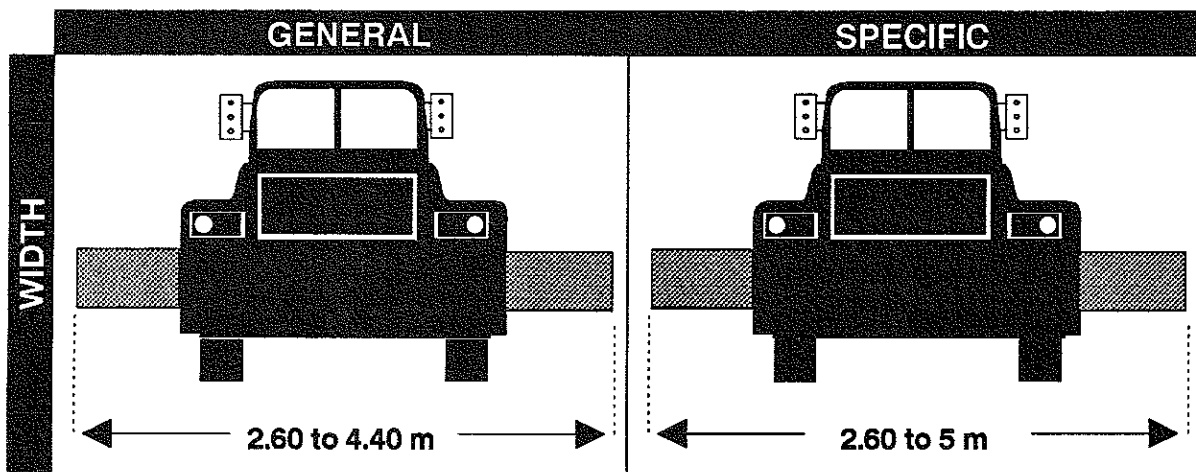

(b) height: 4.30 m or 5 m in the case of a specific permit;

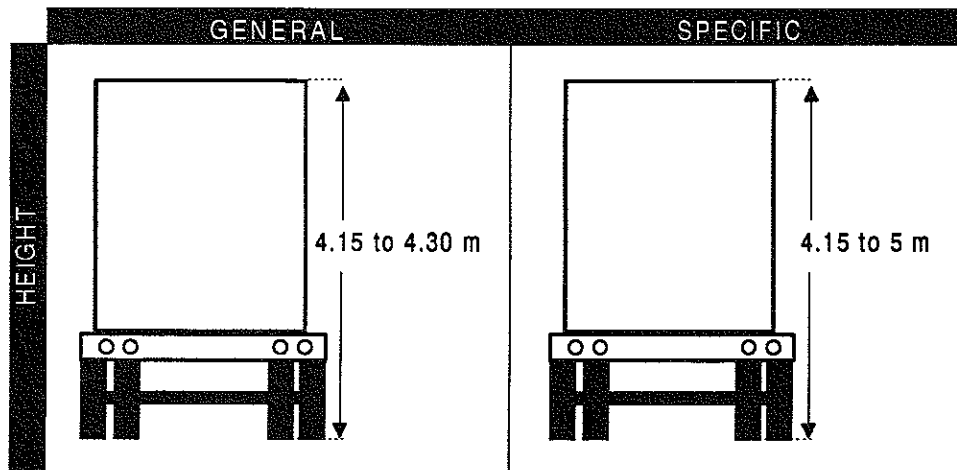

- (c) *length: 21 m for cranes, 17 m for any other motor vehicle, 27.50 m for a combination of 2 road vehicles including a combination of road vehicles consisting of a crane and a trailer, 30 m for a combination of 3 road vehicles consisting of a tractor, a hauled dolly and a semi-trailer or 40 m for any combination of road vehicles covered by a specific permit;*

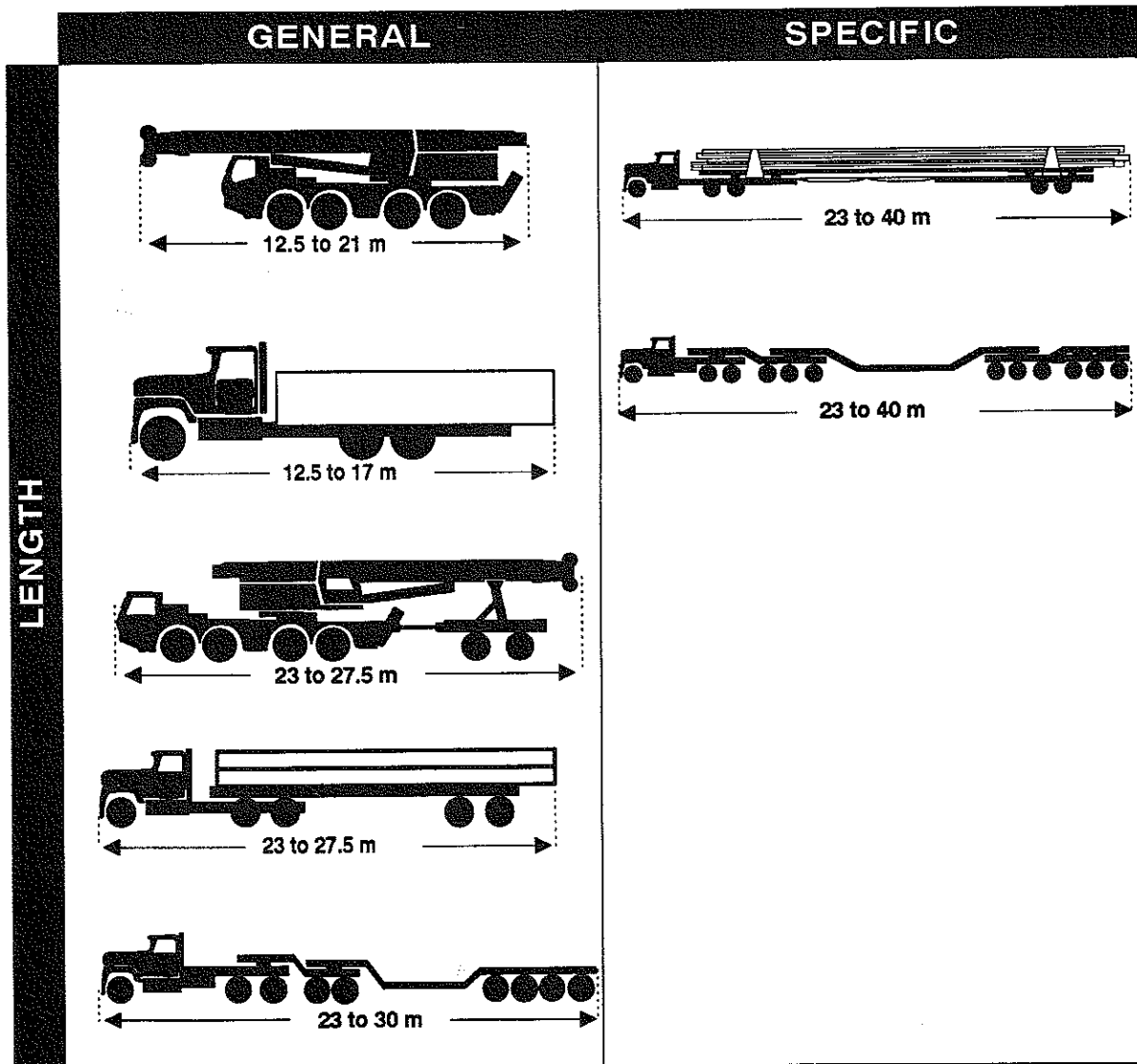

- (d) front or rear overhang created by equipment or load: 4 m in the front for cranes and for vehicles used in snow removal, 2 m in the front for any other road vehicle, 6 m in the rear for trees loaded lengthwise and 4 m in the rear for any other load or equipment.

Until 31 December 2008, the 4 metre limit in the front also applies to the lifting device of a tractor whose model year is prior to 1993. Until 31 December 1995, the 6-metre limit in the rear also applies to posts when they are transported on a trailer.

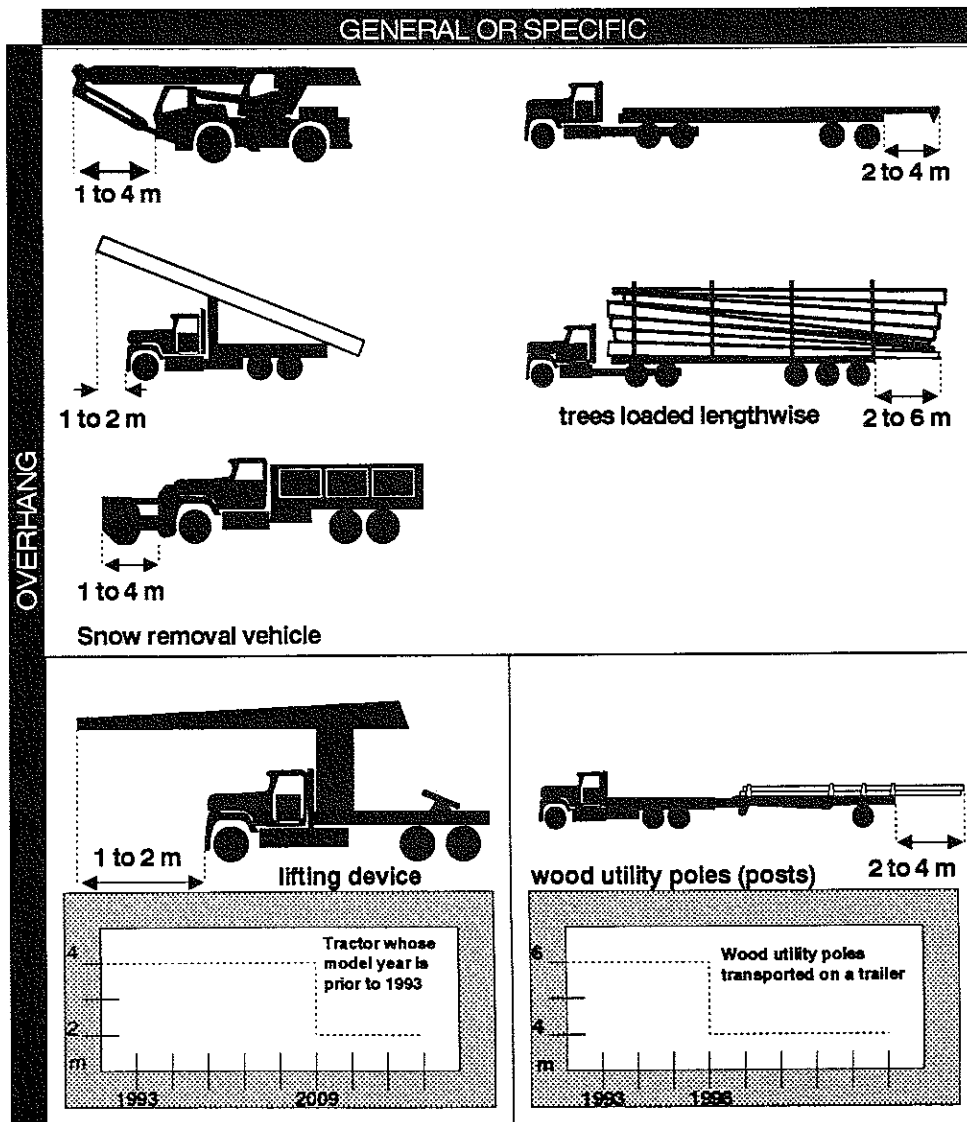

(2) Class 2:

a permit for transporting *a prefabricated building*, not exceeding the following dimensions:

(a) width:

- 4.30 m measured for the body of *the building*, plus an additional 10 cm reserved exclusively for protrusions. A specific permit may be issued where the width exceeds 4.30 m without exceeding 5 m;
- 4.60 m at the roof of *an entire building*. A specific permit may be issued where the width exceeds 4.60 m without exceeding 5.30 m;
- 5.05 m at the roof of a *building in sections* provided that the additional 45 cm is located on the side of the right-hand shoulder of the highway and is at least 2.10 m from the ground and provided that the additional 30 cm on the left-hand side is at least 3.65 m from the ground. The additional centimetres are measured from the body of *the house*. A specific permit may be issued where the width exceeds 5.05 m without exceeding 5.75 m.

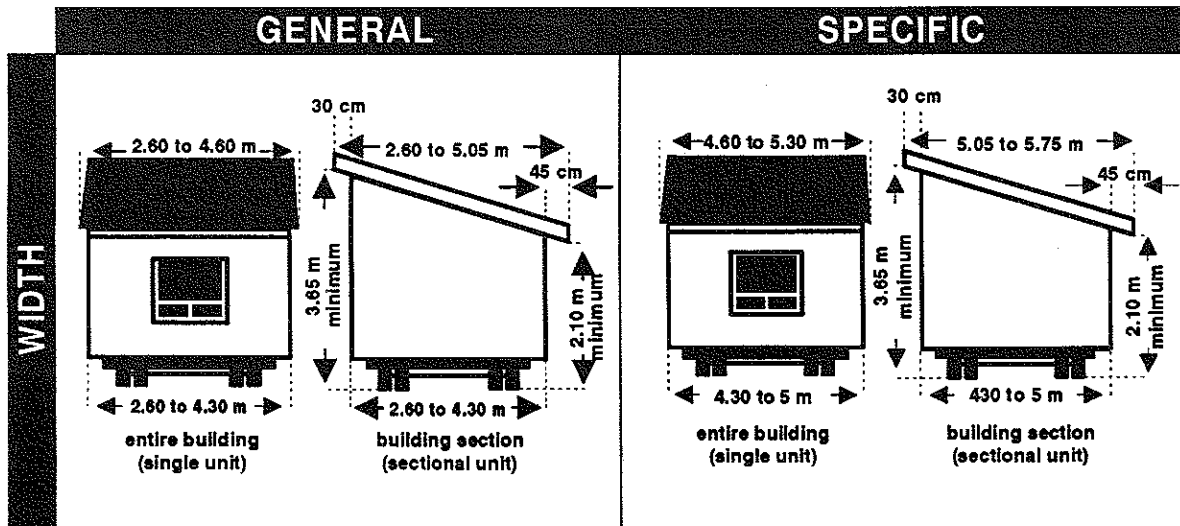

- (b) height: 4.30 m or 5 m in the case of a specific permit;

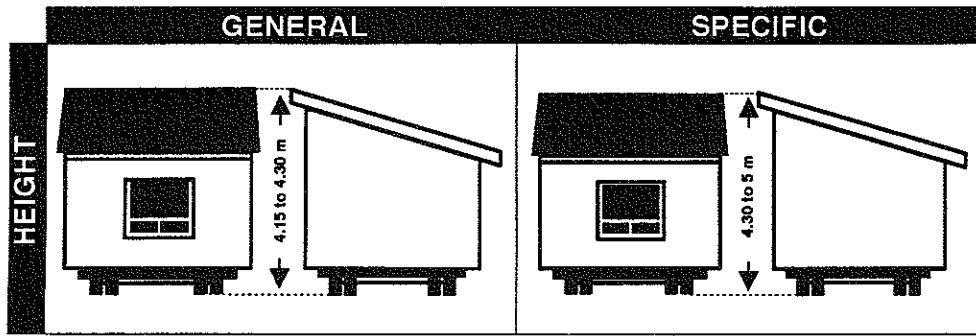

- (c) overall length: 30 m;

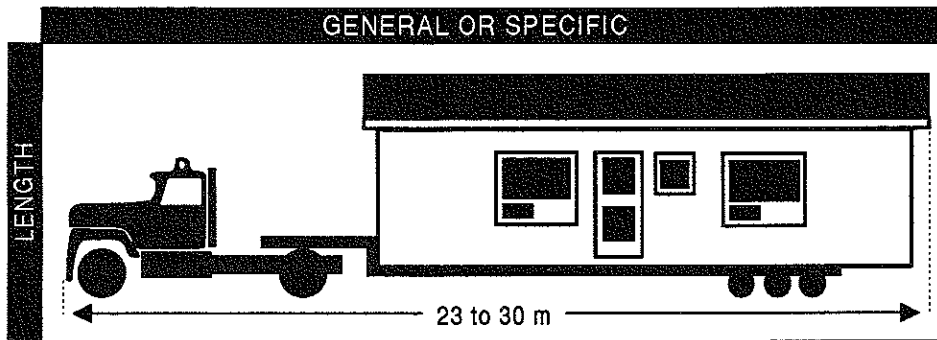

- (d) overhang in rear measured between the chassis of the semi-trailer and the *rear extremity of the building*: 5 m.

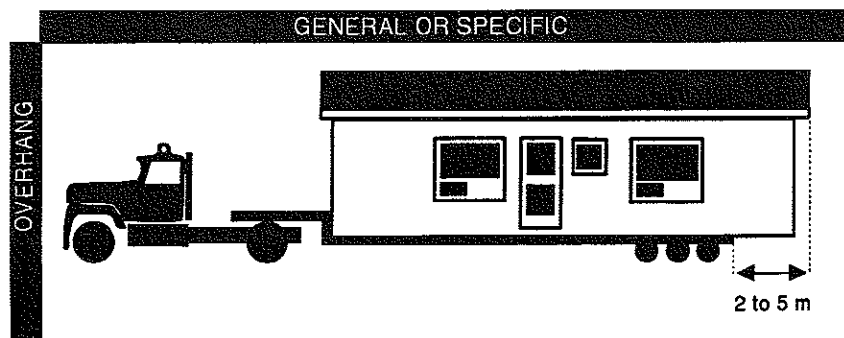



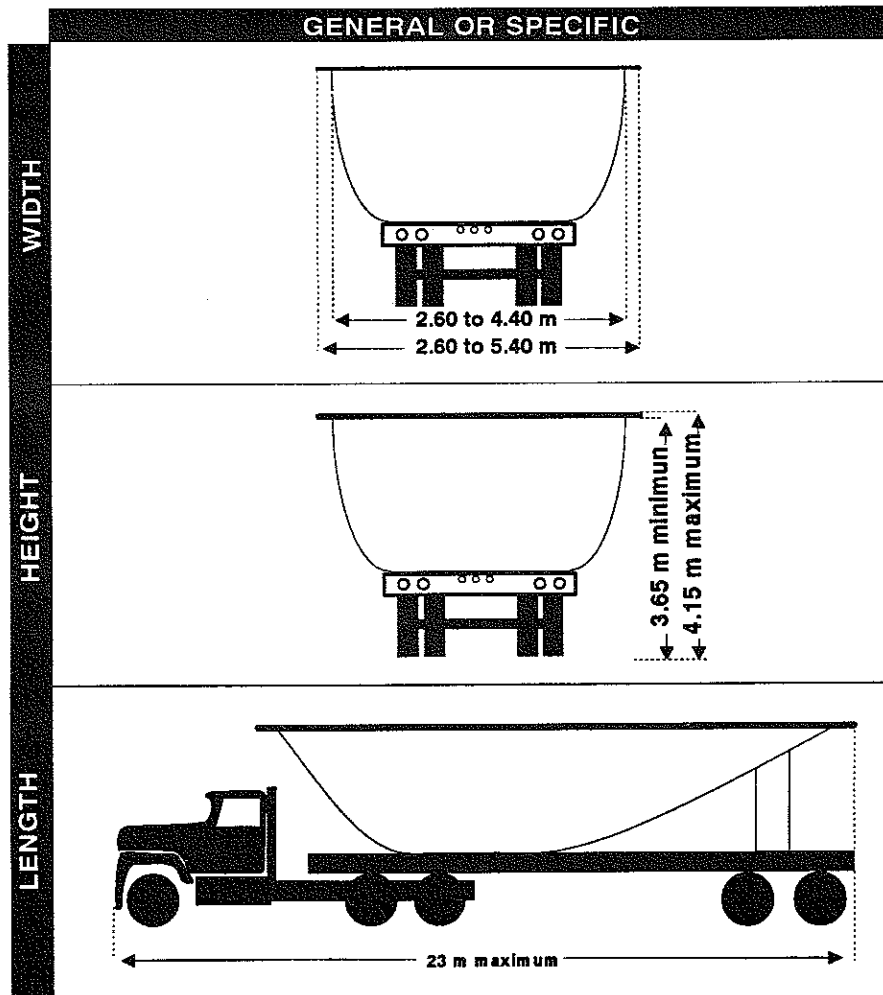

(3) Class 3:

a permit for transporting a swimming pool whose width at the base is less than 4.40 m plus an additional 1 m in the upper part at a height of at least 3.65 m from the ground; the height and length shall comply with the standards established by the *Vehicle Load and Size Limits Regulation made by Order in Council 1299-91 dated 18 September 1991*.

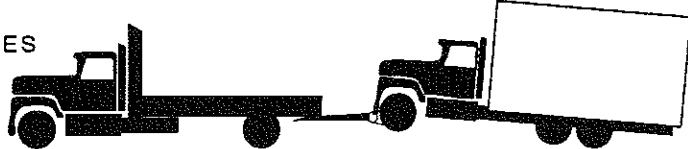
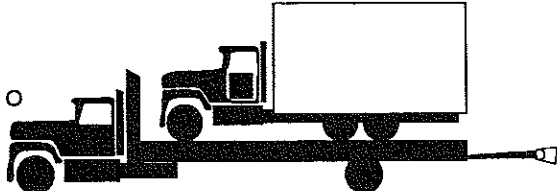

(4) Class 4:

a permit for a tow truck hauling another vehicle that has been in an accident or has broken down, without a load, without exceeding, for the load on the single or tandem rear axle of the tow truck and for its total loaded mass, the maximums prescribed in Schedule 1.

GENERAL OR SPECIFIC	
	 <p>maximum of 15 000 kg according to tires</p>
	 <p>maximum of 30 000 kg according to tires and axle spread (spacing between the axles)</p>
YES	
NO	
NO	

(5) Class 5:

a permit for transporting an indivisible load with a vehicle that is outsized with respect to the axle load or total loaded mass, including a vehicle that was manufactured as an outsized vehicle, without exceeding the maximums prescribed in Schedule 1.

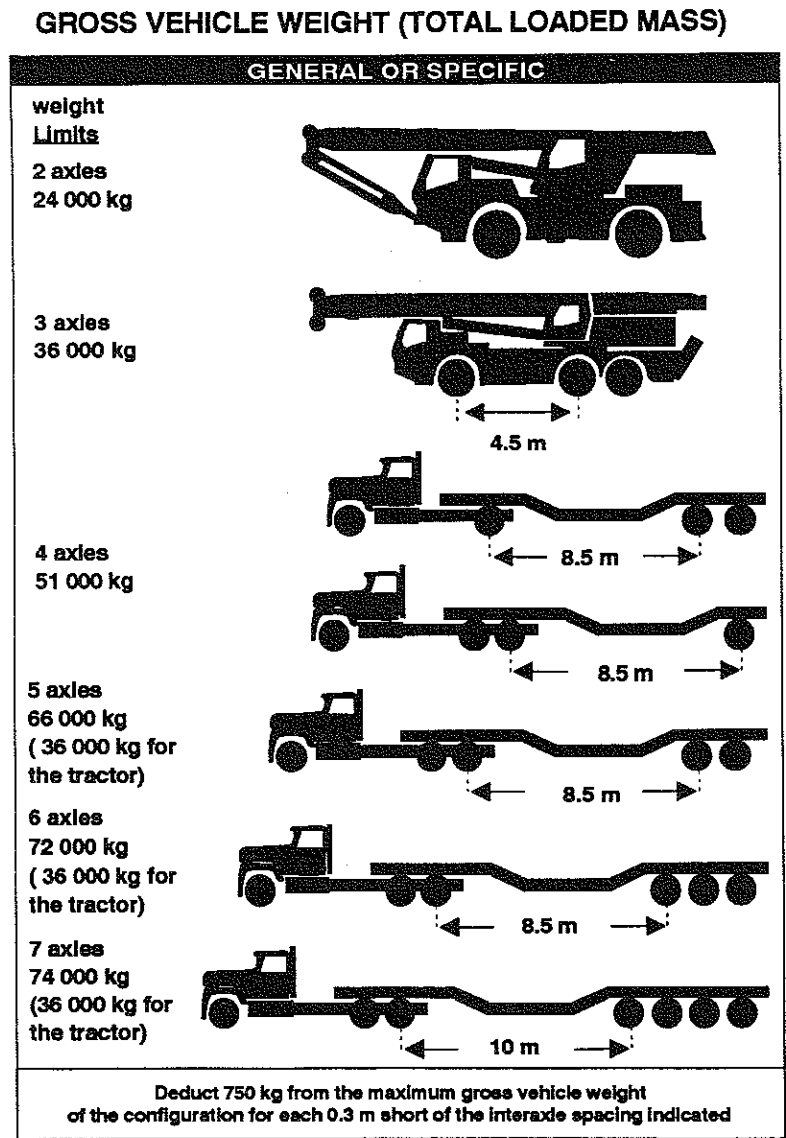

GROSS VEHICLE WEIGHT (TOTAL LOADED MASS)

GENERAL OR SPECIFIC	
<p>Weight Limits</p> <p>7 or 8 axles 76 000 kg (29 000 kg for the tractor, 42 000 kg for the tractor and jeep dolly)</p>	
<p>8 or 9 axles 79 000 kg (26 000 kg for the tractor, 45 000 kg for the tractor and jeep dolly)</p>	
<p>Until December 31st 1997</p>	
<p>Allowable loads during a thaw appear on permits for combinations of 3 road vehicles</p>	
<p>Deduct 750 kg from the maximum gross vehicle weight of the configuration for each 0.3 m short of the Interaxle spacing indicated</p>	

Note: A Class 5 permit is not issued for a vehicle that could comply with the requirements of the Vehicle Load and Size Limits Regulation. For instance, vehicles with a concrete pump or used to dig wells could comply with the Regulation's requirements and therefore may not obtain special permits.

(6) Class 6:

a permit authorizing the travel of an outsized vehicle, including a vehicle that was manufactured as an outsized vehicle, in any of the following cases:

- (a) where its configuration is not prescribed in Schedule 1;*
- (b) where its axle load or its total loaded mass, including the load and equipment, exceeds the limits prescribed for a Class 5 permit;*
- (c) where a sign prohibits the travel of such vehicle;*
- (d) where the travel of such vehicle is prohibited during a thaw.*

Such permit is specific; however, it may be general where it is issued for repetitive transport of the same nature on a single specified route, where it is issued for all public highways or where it is issued for the network of autoroutes referred to in Schedule 4.

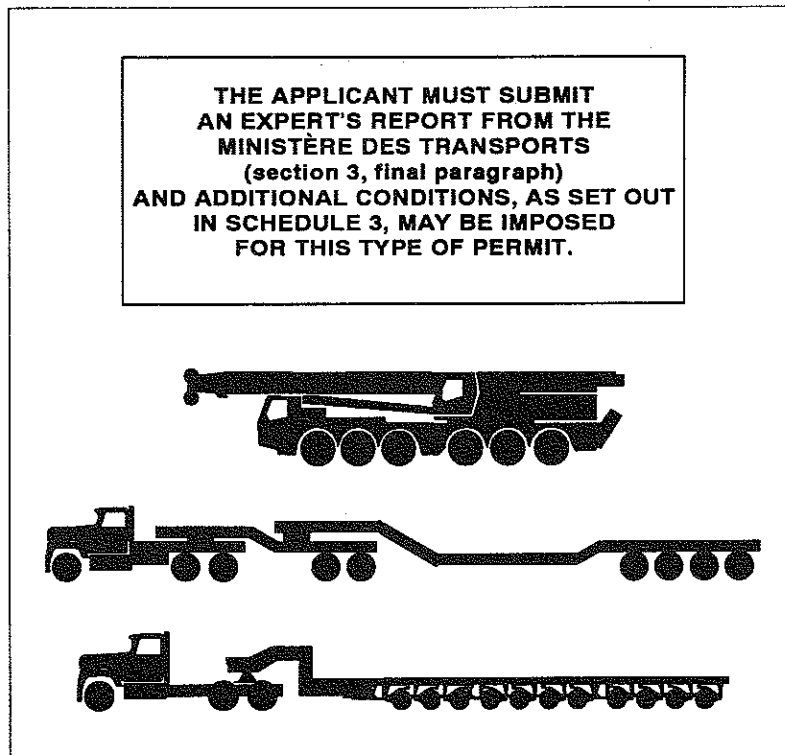

(7) Class 7:

a permit authorizing limits that, including the load and equipment, exceeds the limits of a Class 1 general permit. Such permit is specific; however, it may be general in the case of a vehicle that is oversized because of a piece of equipment or in the case of repetitive transport of the same nature where the load dimensions making the vehicle oversized are specified, and for a single specified route.

THE APPLICANT MUST SUBMIT AN EXPERT'S REPORT
FROM THE MINISTÈRE DES TRANSPORTS
(section 3, final paragraph)
AND ADDITIONAL CONDITIONS, AS SET OUT
IN SCHEDULE 3, MAY BE IMPOSED
FOR THIS TYPE OF PERMIT.

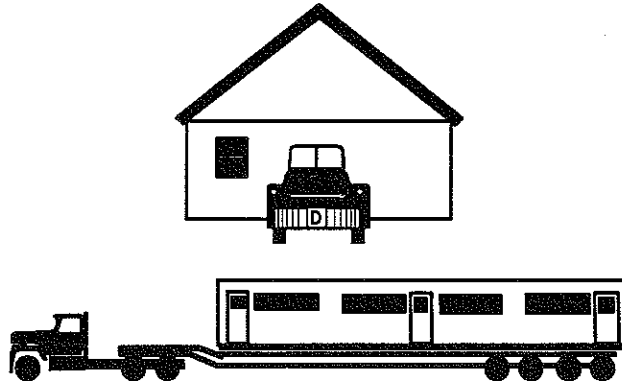

CHAPTER II
CONDITIONS FOR ISSUE, FORM AND CONTENT OF A PERMIT

3. *To obtain a special permit, an applicant must:*
- (a) *furnish all the information prescribed in sections 3.1 and 3.2 on the form provided by the Société de l'assurance automobile du Québec and sign the form;*
 - (b) *pay any sum owing to the Société.*

In the case of a Class 6 permit for a crane, the applicant must also provide a copy of the certificate, signed by an engineer, attesting to the characteristics of the crane provided for in paragraph 7 of section 3.1 and in paragraphs 5 to 8 of section 3.2, as well as the crane's year of manufacture, maximum speed and lifting capacity, a list of its removable equipment included in the mass declared pursuant to paragraph 7 of section 3.2 and, where a Class 1 or Class 7 permit is required, the characteristics provided for in paragraph 1 of section 3.2.

In the case of a Class 7 permit authorizing a height exceeding 5 m, the applicant must also, from 24 May 1994, file an agreement entered into with the public utility companies pertaining to the moving of wires and cables along the route during the period of validity of the permit, or an affidavit in which the applicant swears or solemnly affirms that there is no wire or cable above the route for which the permit is being applied.

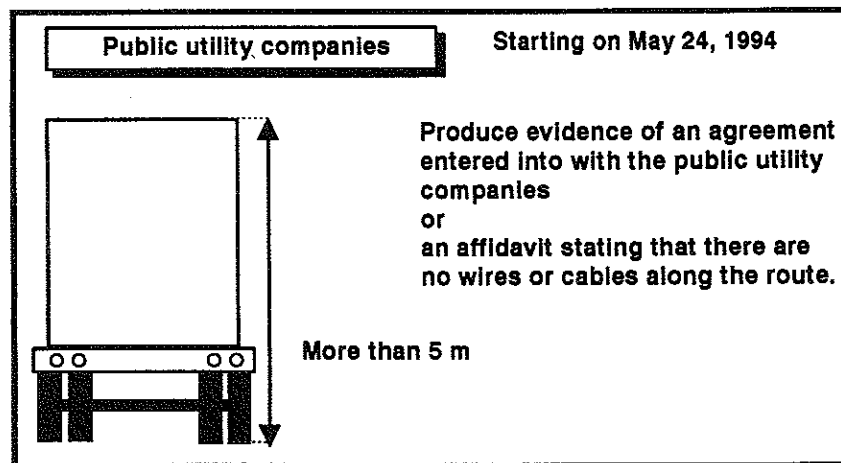

He must also, in the case of a Class 6 or Class 7 permit, submit an expert's report from the Ministère des Transports certifying the feasibility of the planned transport.

- 3.1 *To obtain a special permit, an applicant must furnish the following information:*
- (1) *his or its name, where applicable, the name used to conduct his or its activity, his first name in the case of a natural person, and, where applicable, the identification number issued by the Société;*
 - (2) *his or its address, whether the address of the principal residence in the case of a natural person or the address of the place of business in the case of a legal person;*
 - (3) *the number of the trucking permit or licence in the case of a transport for remuneration or a statement to the effect that the applicant owns the load in the case of a transport on his or its own account, except in the case of a crane or in the case of a Class 2 or Class 4 permit;*

Pursuant to sections 463 and 473 of the Highway Safety Code, special permits are issued to the owner or lessee of an oversized vehicle or to a carrier responsible for such a vehicle. Therefore, a transport broker (unless he is a carrier as defined in section 519.2 of the Code) and a shipper who subcontracts truck transportation services may not obtain special permits. Trucking permits or licences are issued by the Commission de transport du Québec in accordance with the Act respecting truck transportation.

- (4) *the category and class of the permit applied for;*
- (5) *his or its specific needs, if any, respecting the date of coming into force and duration of the permit;*
- (6) *the number of the previous special permit, where applicable;*
- (7) *the make and model of the oversized vehicle in the case of special mobile equipment, a crane, a semi-trailer equipped with more than 4 axles or a trailer equipped with more than 4 axles;*
- (8) *the name of the broker, if any, and the identification number issued to him by the Société, where applicable;*
- (9) *a statement that the load and equipment cannot be arranged or divided in such a way so that the road vehicle or combination of road vehicles complies with the standards established by the Vehicle Load and Size Limits Regulation, except if the application is for a Class 4 permit.*

- 3.2 *An applicant must, in addition to the information prescribed in section 3.1, furnish the following information according to the category and class of the permit applied for:*
- (1) *for a Class 1, Class 2 or Class 3 specific permit or for a Class 7 permit, the overhangs and the dimensions of the vehicle, including the load and equipment;*
 - (2) *for a Class 1 specific permit or for a Class 6 or Class 7 permit, the nature of the load;*
 - (3) *for a Class 4, Class 5 or Class 6 permit, from 28 February 1994, a statement to the effect that the drivers working for the applicant are familiar with the Répertoire des ponts et viaducs faisant l'objet de limitations de poids (Directory of Bridges and Overpasses with Weight Restrictions) published by the ministère des Transports du Québec;*
 - (4) *for a Class 4, Class 5, Class 6 or Class 7 permit, the type of vehicle;*
 - (5) *for a Class 4 or Class 5 permit or for a class 6 general permit authorizing a vehicle whose load limits are provided for in Schedule 1 to travel on a bridge where a sign prohibits travel by oversized vehicles, the licence plate number; for a Class 1 specific permit or for a Class 6 or Class 7 permit, the licence plate number of the semi-trailer, trailer, crane, special mobile equipment or single unit vehicle;*
 - (6) *for a Class 4, Class 5 or Class 6 permit, the minimum width of the tires, the number of tires per axle, the minimum spaces between axles and groups of axles, the minimum capacity of the tires per axle and the capacity of the axles controlled by the steering wheel;*
 - (7) *for a Class 6 permit, the axle load and the total loaded mass;*
 - (8) *for a Class 4, Class 5 or Class 6 permit and for each axle:*
 - (a) *the type of axle;*
 - (b) *the type of suspension;*
 - (c) *a statement to the effect that the mass that can be measured under the wheels of each axle that is part of the groups of axles that have the characteristics of a tandem, triple or quadruple axle is distributed equally at all times, within a margin of 1 000 kg;*

SEE SECTION 0.1

The characteristics to be considered are the type of suspension, the axle spread and the capacity to equally distribute the load. The required statement applies only to the groups of axles that comply with the definitions given.

- (9) *for a specific permit of any class, the point of origin, the destination and the roads used;*
- (10) *for a Class 6 or Class 7 general permit, the roads used and, in the case of repetitive transport of the same nature and for a single specified route, the point of origin and the destination;*
- (11) *for a Class 6 permit, where applicable, an indication as to whether the application applies to the outward trip or the return trip and, in each case, an indication as to whether the vehicle is empty or loaded;*
- (12) *for a Class 7 general permit, the dimensions of the load that make the vehicle oversized, where applicable.*

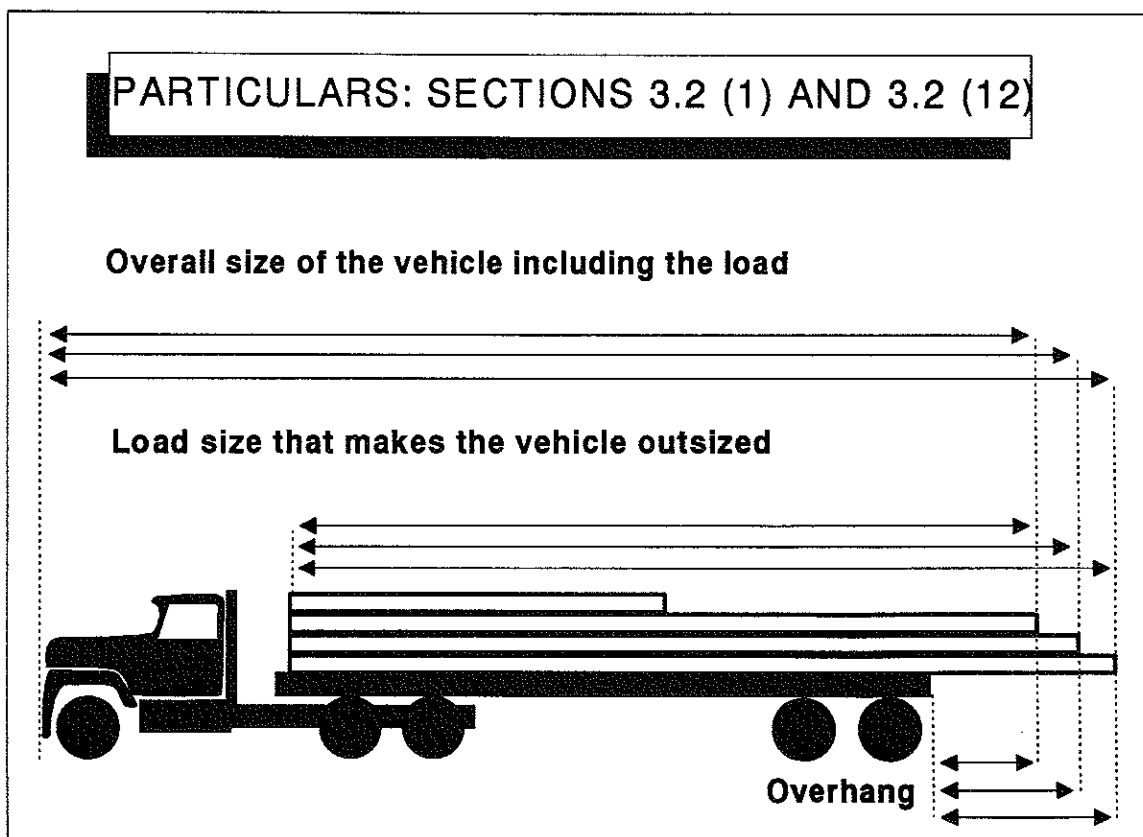

4. *A permit must be rectangular in shape, have a surface area of at least 100 cm² and contain the following information:*
- (1) *its number;*
 - (2) *the date of its issue;*
 - (3) *the date of its coming into force, which must not be later than 3 months after the date of its issue;*
 - (4) *the date of its expiry;*
 - (5) *its category and class;*
 - (6) *the name of the holder, where applicable, the name used to conduct his or its activity, his first name in the case of a natural person and, where applicable, the identification number issued by the Société;*
 - (7) *the address of the holder, whether the address of the principal residence in the case of natural person or the address of the place of business in the case of a legal person;*
 - (8) *the signature of the holder and the logo of the Société;*
 - (9) *the type of vehicle in the case of a Class 4, Class 5, Class 6 or Class 7 permit;*
 - (10) *the width and minimum capacity of the tires, the number of tires per axle and the minimum spaces between the axles and groups of axles in the case of a Class 4, Class 5 or Class 6 permit;*
 - (11) *the number of the trucking permit or licence in the case of transport for remuneration, except in the case of a crane or in the case of a Class 2 or Class 4 permit;*
 - (12) *the licence plate number prescribed in paragraph 5 of section 3.2 in the case of a Class 1 specific permit or of a Class 4, Class 5, Class 6 or Class 7 permit;*
 - (13) *the authorized limits in the case of a Class 1, Class 2 or Class 3 specific permit or of a Class 4, Class 5, Class 6 or Class 7 permit;*
 - (14) *the characteristics furnished pursuant to subparagraphs (a) and (b) of paragraph 8 of section 3.2 for each group of axles that has the characteristics of a tandem, triple or quadruple axle in the case of a Class 4, Class 5 or Class 6 permit;*

- (15) *the nature of the load in the case of a Class 1 specific permit or of a Class 6 or Class 7 permit;*
- (16) *the point of origin, the destination and the roads to be used in the case of a specific permit;*
- (17) *the roads to be used in the case of Class 6 or Class 7 general permit and the point of origin and the destination in the case of repetitive transport of the same nature and for a single specified route;*
- (18) *an indication as to whether the permit is for the outward trip or the return trip and, in each case, an indication as to whether the vehicle is empty or loaded in both instances in the case of a Class 6 permit;*
- (19) *the load limits authorized during a thaw in the case of a Class 5 permit issued for a combination of 3 road vehicles consisting of a tractor, a hauled dolly and a semi-trailer;*
- (20) *the additional conditions provided for in Schedule 3, which are imposed to ensure the feasibility of the transport, in the case of a Class 6 or Class 7 permit;*
- (21) *an indication as to whether a schedule is enclosed with the permit, where applicable, and the number of pages in the schedule.*

CHAPTER III
CONDITIONS ATTACHED TO PERMITS

5. A special permit holder must:
- (1) sign the permit or have it signed by his representative;
 - (2) verify that the highway system permits the movement of traffic for the dimensions and loads carried;

Before departing, the permit holder must ensure that there are no conflicts with:

- weight limits on bridges;
- damaged roads;
- maintenance and construction work;
- inappropriate road design (junctions, sharp curves, etc.);
- low highway structures;
- etc.

- (3) comply with the requirements in Chapter IV regarding warning signals and traffic rules;

- (4) *verify that the load and equipment cannot be arranged or divided in such a way so that the road vehicle or combination of road vehicles complies with the standards established by the Vehicle Load and Size Limits Regulation, except in the case of a Class 4 permit;*

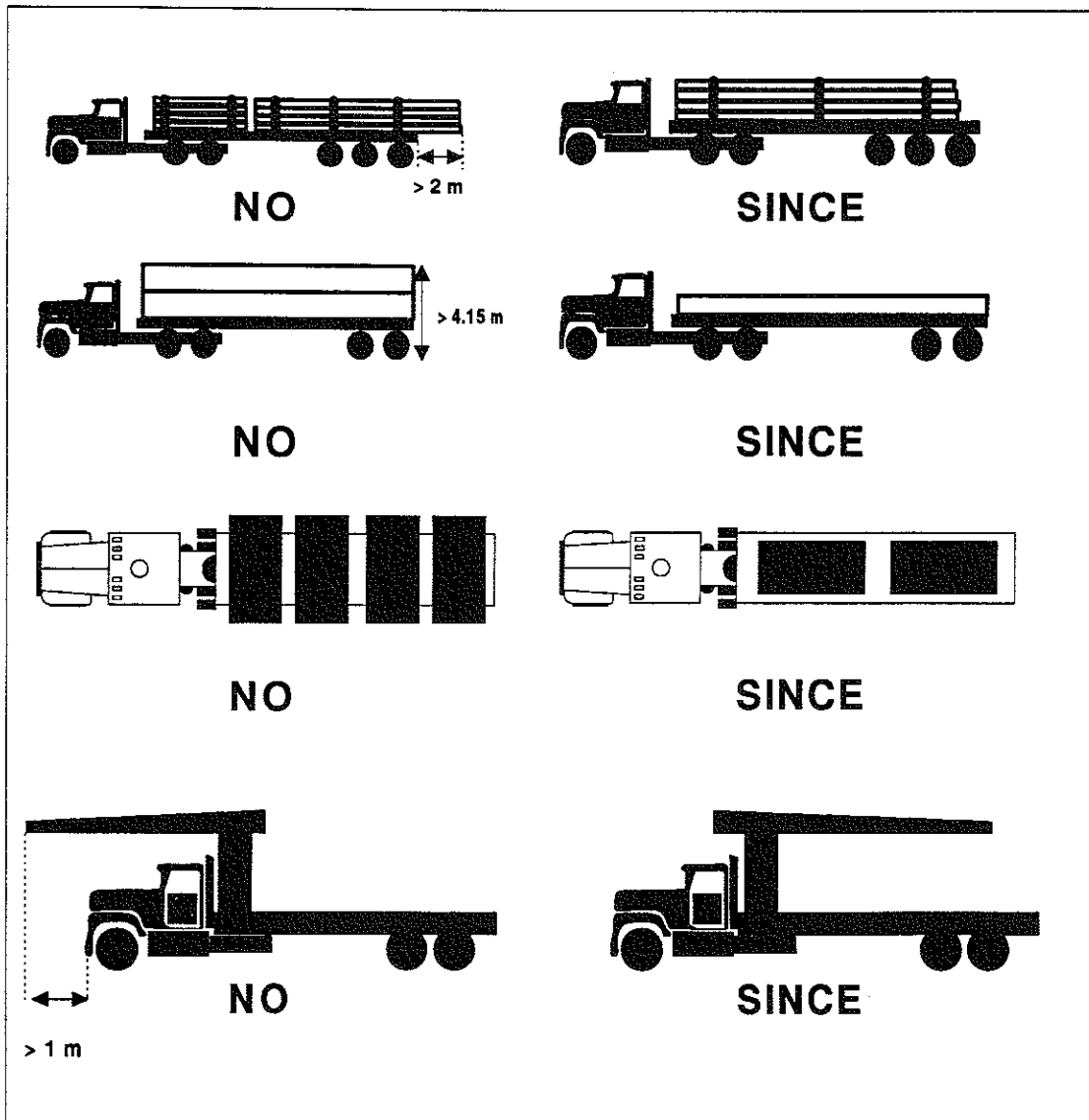

- (5) ensure that the vehicle travels with the headlights turned on;
- (6) *not drive a vehicle covered by a Class 4 or Class 5 permit or allow such vehicle to travel on a bridge where a sign prohibits the travel of oversized vehicles;*

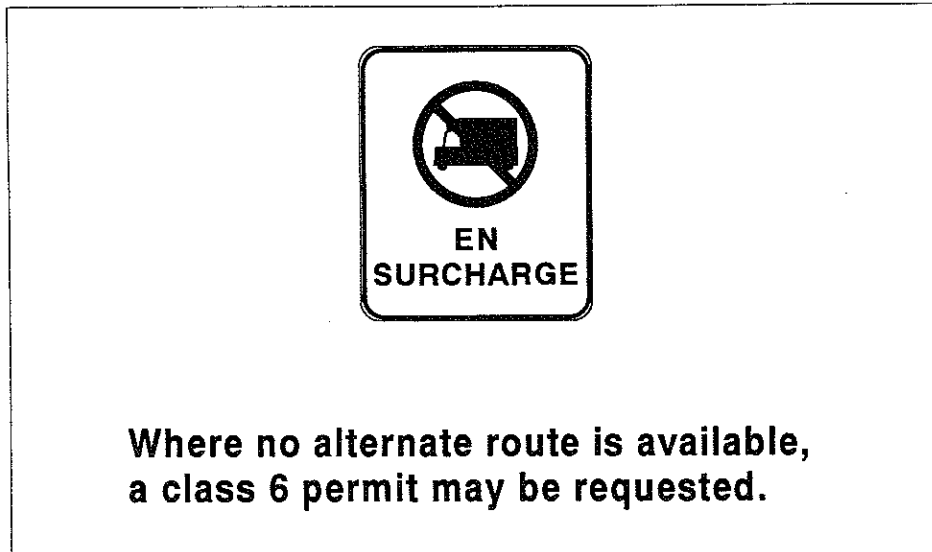

- (7) *not drive a vehicle covered by a Class 5 permit or allow such vehicle to travel during a thaw, unless the permit makes provision for the use of a hauled dolly;*

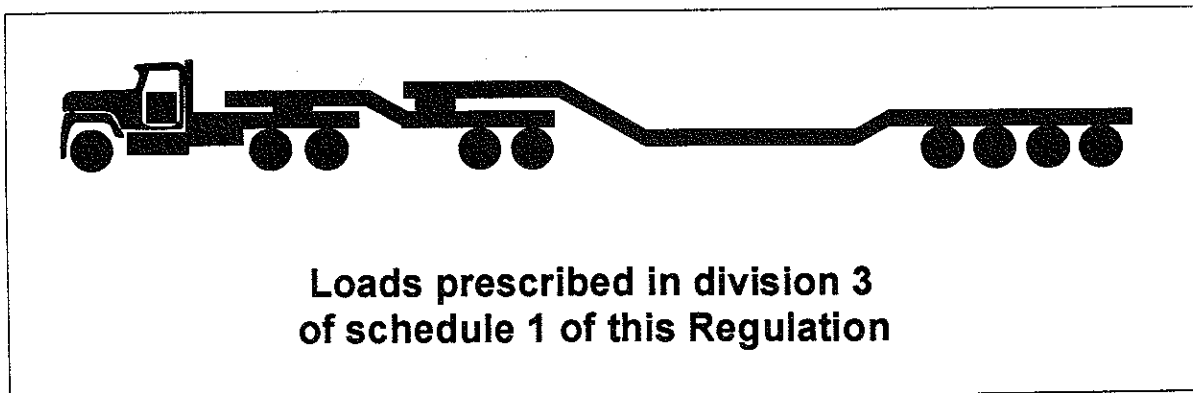

- (8) *make sure that a vehicle manufactured as an oversized vehicle and covered by a Class 1 or Class 7 permit travels unloaded, travels with a load made up of a single object or travels with a load made up of one object or more, of which at least one requires the use of a vehicle manufactured as an oversized vehicle, provided that the transport of an additional object does not render the vehicle oversized with respect to another dimension or the load;*

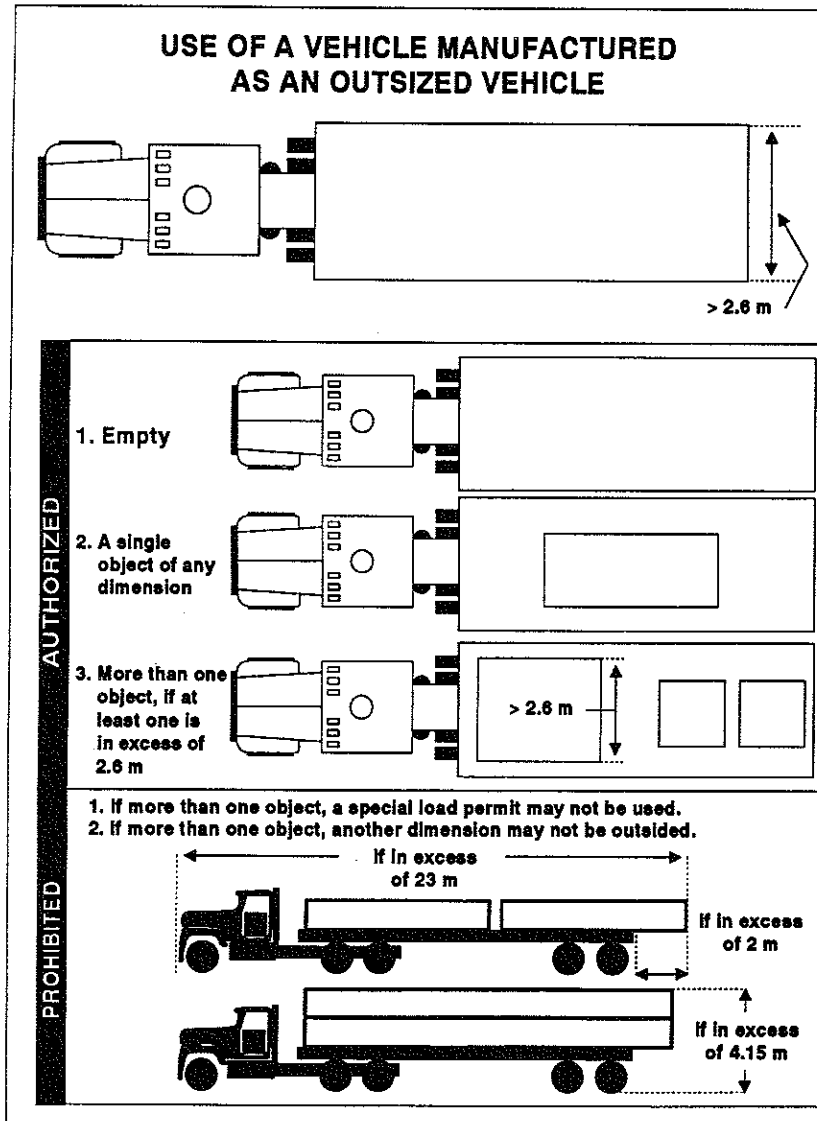

- (9) *comply with the load limits and dimensions prescribed on the permit, including those applicable to the class of the permit, and with the additional conditions prescribed in Schedule 3 and specified by the permit;*
- (10) *make sure that all the characteristics of the vehicle used provided for in paragraphs 9, 12, 14 and 15 of section 4 are identical to the characteristics mentioned in the permit and that all the characteristics provided for in paragraph 10 of the same section are identical or superior to the characteristics mentioned on the permit;*
- (11) *make sure that a combination of vehicles outsized with respect to height and covered by a Class 1 or Class 7 permit includes a semi-trailer lower than the king pin of its coupling device or a trailer whose loading platform is not more than 1 m from the ground, unless the permit expressly authorizes the use of another type of trailer or semi-trailer;*

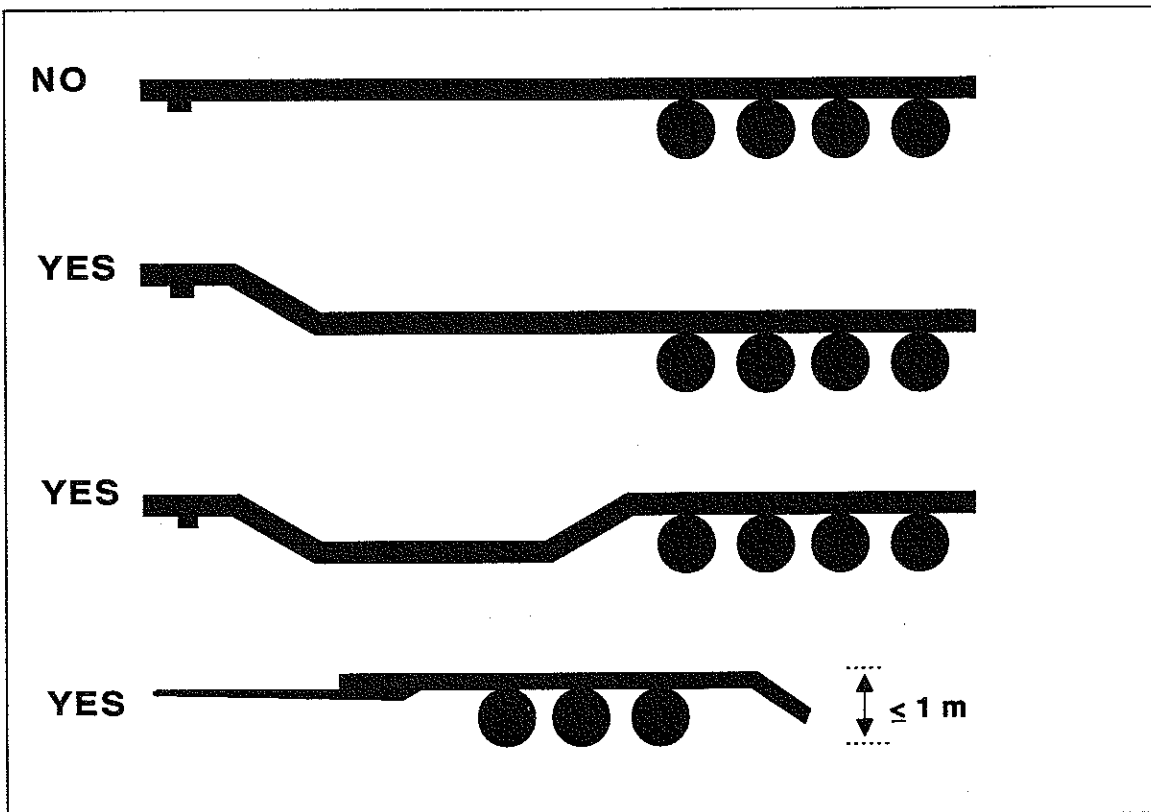

- (12) *make sure that a hauled dolly used under a general Class 1 permit or Class 5 permit is removed, where the total loaded mass of the combination of vehicles is less than 65 000 kg and where its length exceeds 23 m, except if the vehicle travels unloaded or during a thaw;*

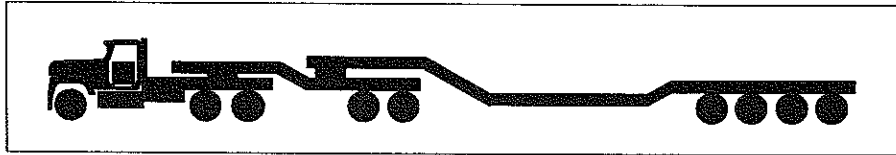

- (13) *make sure that a combination of vehicles covered by a Class 7 permit authorizing a rear overhang greater than 4 m includes a pole or expandable body platform trailer or semi-trailer to reduce the overhang, unless the permit expressly authorizes the use of another type of trailer or semi-trailer.*

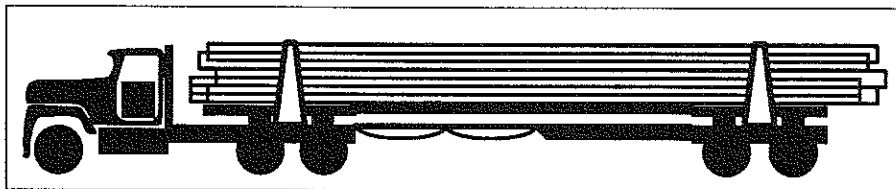

Notwithstanding the foregoing, the prohibition to travel during a thaw set forth in subparagraph 7 does not apply:

- (1) *on the special class public highway described in the Vehicle Load and Size Limits Regulation;*

Special class public highway

Included in this class is the public highway leading to James Bay and beginning at the intersection of the Industrial Park Road and highway No. 109 between Amos and Matagami, the intersection being located at chain number 145-19.

- (2) *where emergency measures are implemented following a disaster, a derailment or a spill of hazardous substances.*

6. The Société is the person empowered to issue a special permit.

CHAPTER IV
WARNING SIGNALS AND TRAFFIC RULES

DIVISION I - WARNING SIGNALS

7. *A vehicle covered by a special permit must be equipped with:*
- (1) *an amber light operating at a rate of 60 to 90 cycles per minute that has a range of 360° and a lens at least 10 cm in height whose minimum width or diameter at that height is 12 cm. The light must be visible up to a minimum distance of 300 m in every direction not covered by the amber lights of an escort vehicle or by a light complying with paragraph 2;*
 - (2) *an additional light of the same type as that prescribed in paragraph 1, or 2 additional flashing amber lights with a minimum diameter of 17.50 cm, operating at a rate of 60 to 90 cycles per minute, at least 2.25 m apart, where the light installed in accordance with paragraph (1) is not visible in a direction not covered by the amber lights of an escort vehicle. The lights must be installed at least 1.50 m from the ground and be visible up to a minimum distance of 300 m in every direction for which they are required;*

Note: The Highway Safety Code (section 228) stipulates that the flashing or rotating lights may only be used when the vehicle is oversized. At all other times, the lights must be turned off.

A vehicle covered by a special permit must be equipped with:

1st Case: An amber light visible in every direction (360° range) for a distance of not less than 300 m.



If the light is not visible in every direction, it may be replaced by:

2nd Case: An escort;

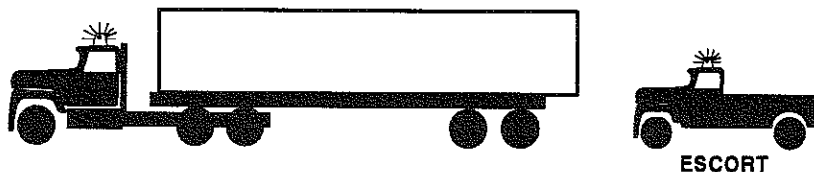

3rd Case: A second amber light of the same type which is visible in the directions obstructed.



4th Case: TWO FLASHING AMBER LIGHTS

Minimum spacing: 2.25 m

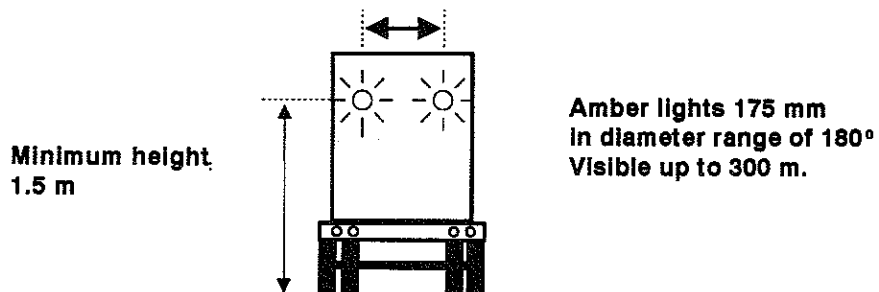

- (3) *boards or hard surfaces complying with the standards established in Schedule 2:*
- (a) *where the width, including the load and equipment, exceeds 3.04 m, the length exceeds 25 m or the height exceeds 4.30 m;*
 - (b) *in the case of a vehicle used in snow removal, where the width exceeds 3.75 m, or where the equipment extends beyond the left side of the vehicle by more than 60 cm or beyond the right side by more than 130 cm, measured at the widest part of the vehicle, excluding its compulsory attachments.*

Such traffic control devices must be placed at the front and rear extremities of the vehicle or of its load; they must be kept free of any object, substance or dirt and must be removed or covered when not required.

This paragraph does not apply to a vehicle covered by a Class 4 permit or a vehicle transporting trees loaded lengthwise or posts;

The bumper or any other **FLAT (NO ANGLE) RIGID** surface on which a cloth sign meeting the standards established in Schedule 2 (size, reflectivity, etc.) is affixed, or onto which the symbols are affixed using the paint and coating described in Schedule 2 is considered a rigid surface in accordance with the standards established in Schedule 2 and is considered the equivalent of the sign more commonly used by the industry. If cloth is used, it must be adequately stretched so as not to blow in the wind.

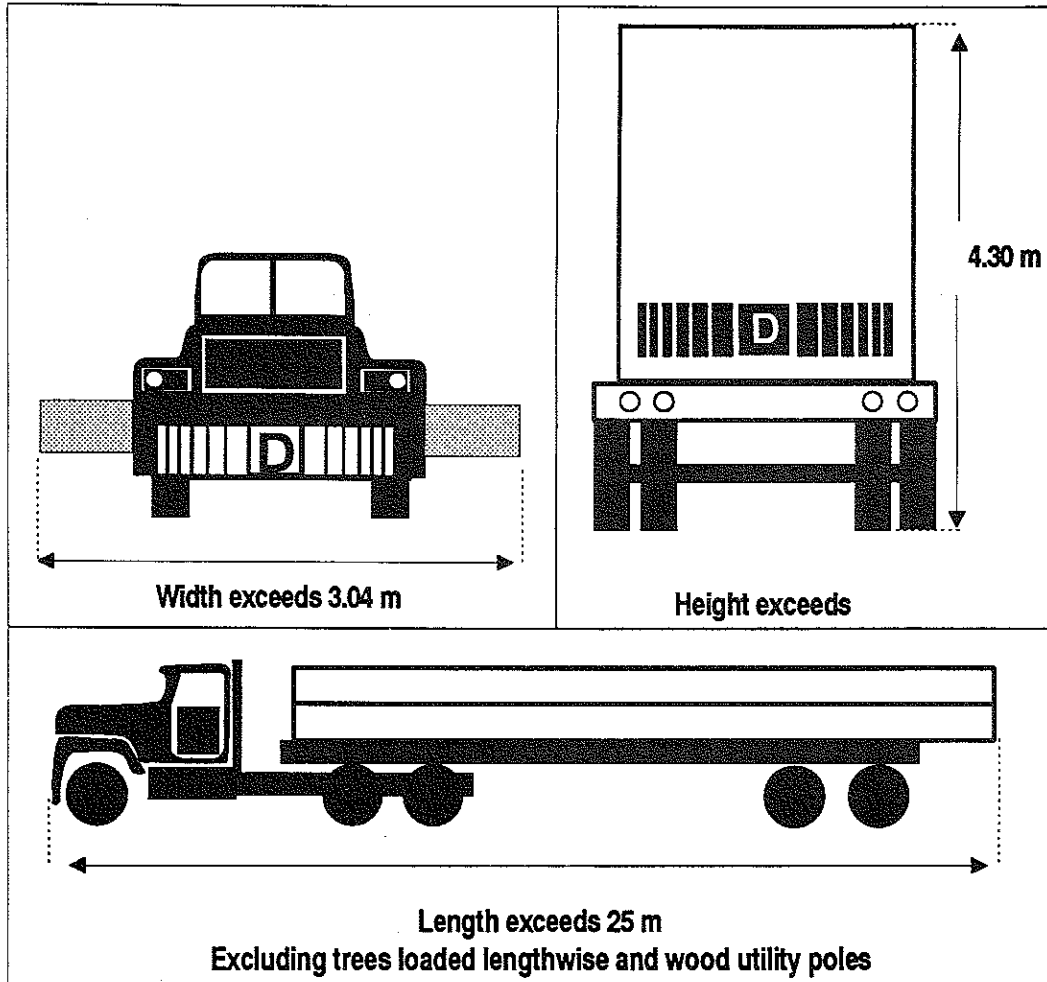

EXCLUDES

SNOW REMOVAL VEHICLES

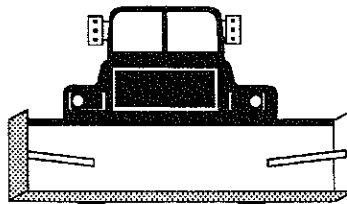

If the width is less than or equal to 3.75 m

If the overhang on the driver's side is less than or equal to 60 cm.

If the overhang on the passenger's side is less than or equal to 130 cm.

- (4) *square red or orange flags, in good condition, measuring 40 cm on each side, attached in at least 2 places so that they wave, or flashing amber lights. Those signals must be used where the load extends beyond the side of the vehicle by more than 30 cm. They must be installed at the widest place at the front and rear extremities of the load and at the front and rear extremities of overhangs extending beyond the width of the load by more than 30 cm and, in the case of posts extending beyond the rear of the loading platform by more than 4 m, every 2 m along each side of the stack of posts extending beyond the rear of the loading platform.*

At night, from 28 February 1994, the flags must be replaced by flashing amber lights.

The lights must have a minimum diameter of 10 cm, operate at a rate of 60 to 90 cycles per minute and be visible up to a minimum distance of 150 m. The lens must be designed so as to allow lateral vision of the light.

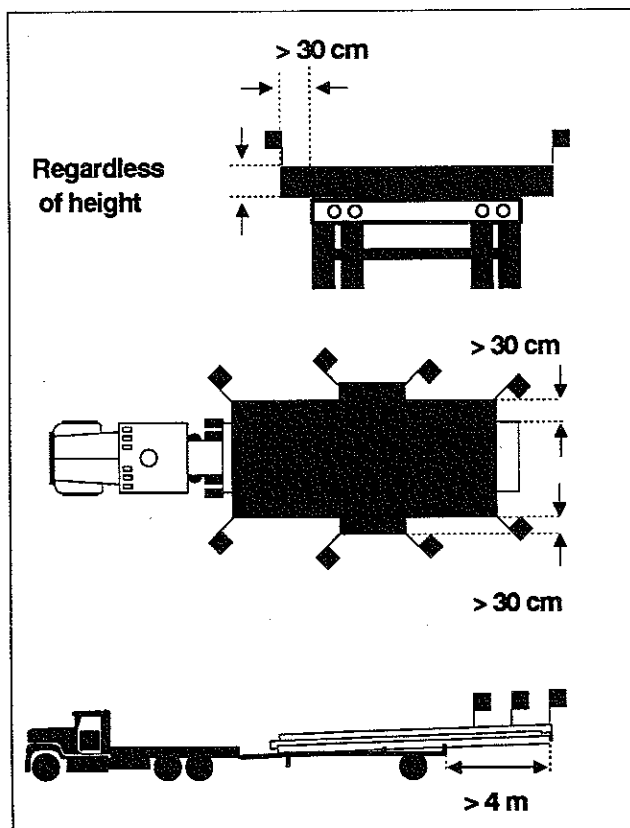

All signals must be installed so that they do not widen the load or the overhangs by more than 12 cm on either side. Notwithstanding the foregoing, the signals intended for the extremities of the load may be arranged in accordance with section 10 in the case of a Class 2 permit; in the case of a lowered semi-trailer, where the load and overhangs that must be signalled are placed lengthwise within the loading platform, those signals may be positioned at the junction of the raised and lowered portions of the semi-trailer. If so, they must be installed on the sides beyond the width of the load and overhangs, without increasing that width by more than 12 cm;

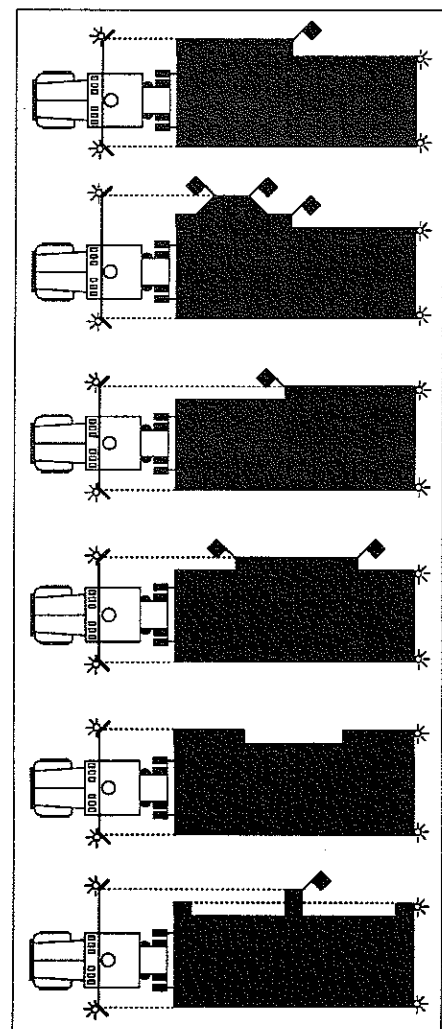
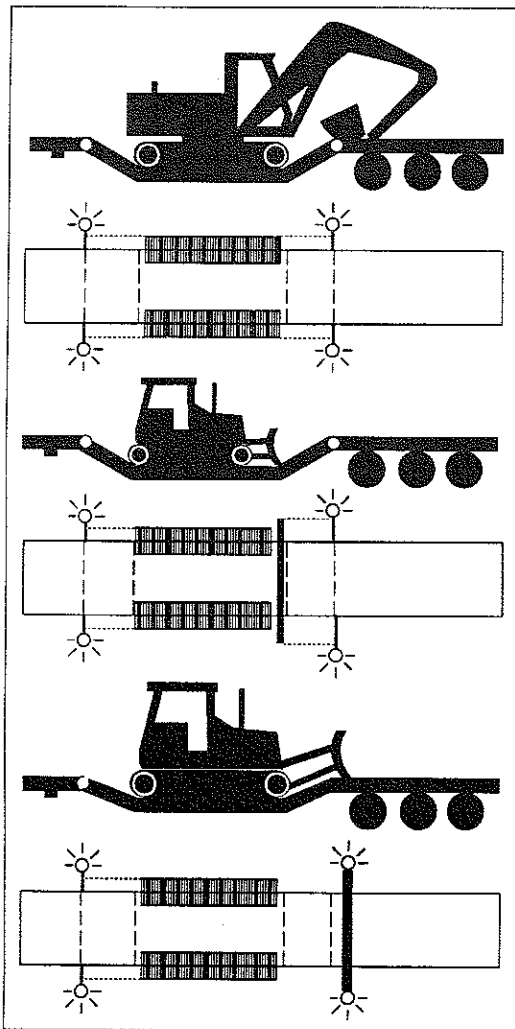

- (5) *in the case of posts or trees loaded lengthwise, the vehicle must also be equipped with a red light with a minimum diameter of 10 cm, visible up to a distance of 150 m and installed at the extremity of the rear overhang.*

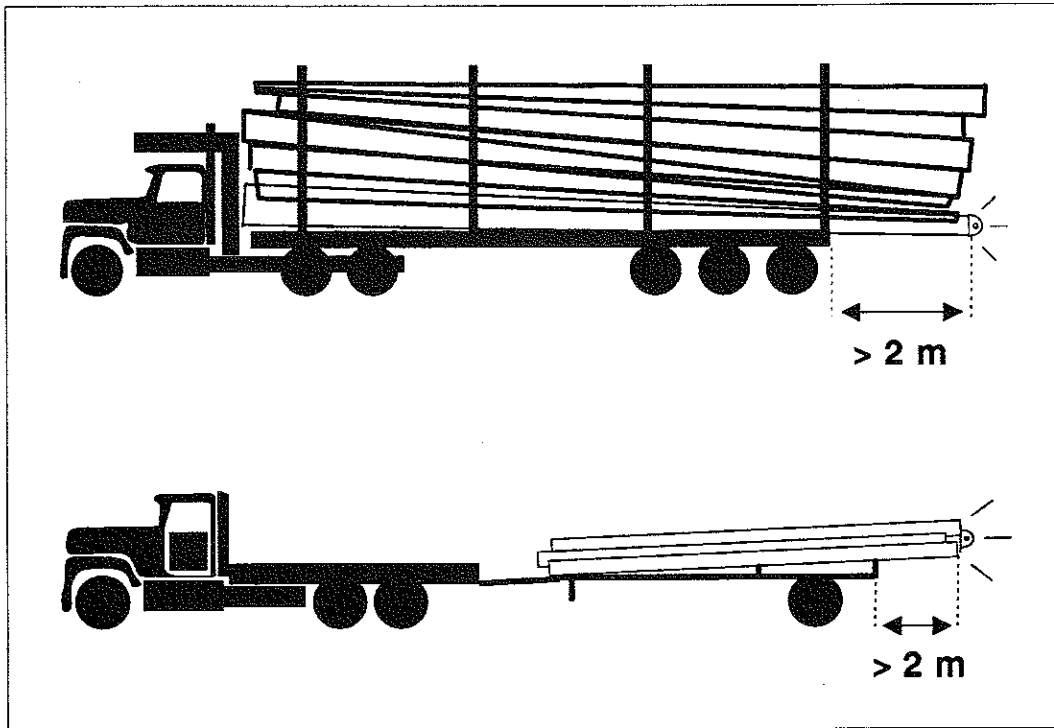

The Regulation requires a red light during the day and at night when transporting wood utility poles or trees loaded lengthwise, where the rear overhang is more than 2 m. The Highway Safety Code (section 474) also requires that any type of load with a rear overhang of more than 1 m be equipped with a red flag or a reflector panel at the rear and, at night, a red light visible from behind and from the sides at a distance of at least 150 m.

8. *Subject to section 10, an escort vehicle is required and must follow the oversized vehicle where, including the load and equipment:*
- (1) *the width of the vehicle exceeds 3.75 m and it travels on a road that has more than one traffic lane in the direction travelled by the vehicle;*
 - (2) *the length exceeds:*
 - (a) *17 m for a single unit vehicle;*
 - (b) *21 m for a crane;*
 - (c) *27.50 m for a combination of 2 road vehicles, including a combination of road vehicles consisting of a crane and a trailer;*
 - (d) *30 m for a combination of 3 vehicles consisting of a tractor, a hauled dolly and a semi-trailer or for a combination of vehicles covered by a Class 2 permit;*
 - (3) *the rear overhang exceeds the limits prescribed in subparagraph (d) of paragraph 1 of section 2.*

Subject to section 10, an escort vehicle is required and must precede the oversized vehicle where, including the load and equipment:





- (1) *the width of the vehicle exceeds 3.75 m and it travels on a road that has only one traffic lane in the direction travelled by the vehicle;*
- (2) *the width of the vehicle exceeds 3.10 m without exceeding 3.75 m and the vehicle travels at night on a road that has only one traffic lane in the direction travelled by the vehicle, except for a vehicle used in snow removal, provided that its equipment does not extend beyond the left side of the vehicle by more than 60 cm and beyond the right side by more than 130 cm, measured at the widest part of the vehicle, excluding its compulsory attachments;*
- (3) *the height of the vehicle exceeds 4.50 m;*
- (4) *the front overhang exceeds the limits prescribed in subparagraph (d) of paragraph 1 of section 2.*

Subject to section 10, 2 escort vehicles (one in front of and the other behind the oversized vehicle) are required where:



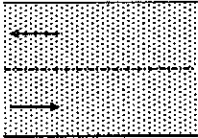
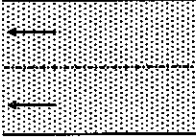
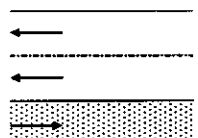
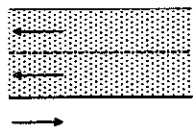

- (1) the width of the vehicle, including the load and equipment, exceeds 4.40 m and the vehicle travels on a road that has only one traffic lane in the direction travelled by the vehicle;*
- (2) the escorted vehicle is covered by one of the conditions provided for in the first paragraph requiring an escort vehicle behind the escorted vehicle and by one of the conditions provided for in the second paragraph requiring an escort vehicle in front of the escorted vehicle.*

Where 2 escorted vehicles travel in convoy, 2 escort vehicles are required, one in front of and the other behind the convoy. Notwithstanding the foregoing, where only one escort vehicle is required for each of the escorted vehicles and that escort vehicle is required to precede or follow each of them, only one escort vehicle is required to precede or follow the convoy.

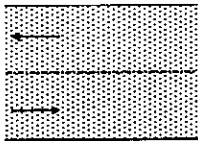
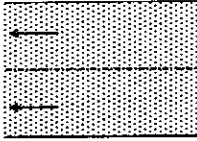
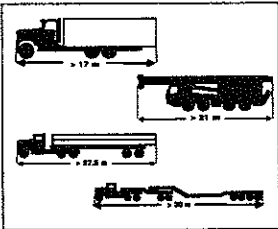

In the case of a Class 2 permit, the width must be measured at the widest part of the building, excluding the roof.

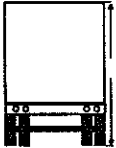
THE ESCORT VEHICLE MUST PRECEDE OR FOLLOW THE OUTSIZED VEHICLE			
DIMENSION OF OUTSIZED VEHICLE	TYPE OF ROAD		
	WITH ONE TRAFFIC LANE IN THE DIRECTION TRAVELLED BY THE VEHICLE	WITH MORE THAN ONE TRAFFIC LANE IN THE DIRECTION TRAVELLED BY THE VEHICLE	
			
			
A	<div style="border: 1px solid black; padding: 2px; display: inline-block;">AT NIGHT</div>  EXCLUDING  <small>SNOW REMOVAL VEHICLES</small> <small>If the width is less than or equal to 3.75 m.</small> <small>If the overhang on the driver's side is less than or equal to 60 cm. If the overhang on the passenger's side is less than or equal to 130 cm.</small>	PRECEDE	NOT REQUIRED
B	 <small>3.75 m to 4.40 m</small>	PRECEDE	FOLLOW
C	 <small>more than 4.40 m</small>	PRECEDE AND FOLLOW	FOLLOW

PROVISIONAL EDITION
 GUIDE TO THE REGULATION RESPECTING SPECIAL PERMITS

THE ESCORT VEHICLE MUST PRECEDE OR FOLLOW THE OUTSIZED VEHICLE		
DIMENSION OF OUTSIZED VEHICLE	TYPE OF ROAD	
	WITH ONE TRAFFIC LANE IN THE DIRECTION TRAVELLED BY THE VEHICLE	WITH MORE THAN ONE TRAFFIC LANE IN THE DIRECTION TRAVELLED BY THE VEHICLE
		
D 	FOLLOW	FOLLOW
E  more than 4 m Except Class 1 for wood utility poles and tree length logs	FOLLOW	FOLLOW
F  more than 4.5 m	PRECEDE	PRECEDE
G  more than 2 m Except Class 1 for lifting devices, cranes and snow removal vehicles	PRECEDE	PRECEDE

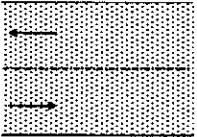
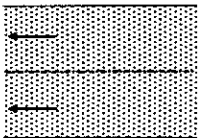
PROVISIONAL EDITION
 GUIDE TO THE REGULATION RESPECTING SPECIAL PERMITS

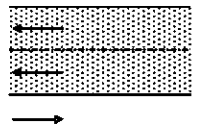
THE ESCORT VEHICLE MUST PRECEDE OR FOLLOW THE OUTSIZED VEHICLE		
COMBINATION OF DIMENSIONS OF OUTSIZED VEHICLES	TYPE OF ROAD	
	WITH ONE TRAFFIC LANE IN THE DIRECTION TRAVELLED BY THE VEHICLE	WITH MORE THAN ONE TRAFFIC LANE IN THE DIRECTION TRAVELLED BY THE VEHICLE
		
		
A AND D OR E	PRECEDE AND FOLLOW	FOLLOW
A AND F OR G	PRECEDE	PRECEDE
B AND D OR E	PRECEDE AND FOLLOW	FOLLOW
B AND F OR G	PRECEDE	PRECEDE AND FOLLOW
C AND D OR E	PRECEDE AND FOLLOW	FOLLOW
D AND F OR G	PRECEDE AND FOLLOW	PRECEDE AND FOLLOW
D OR E AND F OR G	PRECEDE AND FOLLOW	PRECEDE AND FOLLOW

PROVISIONAL EDITION
GUIDE TO THE REGULATION RESPECTING SPECIAL PERMITS

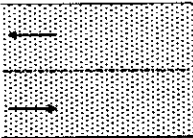
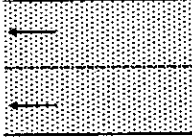
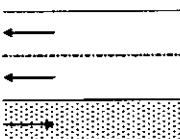
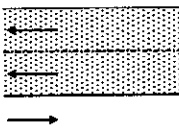
THE ESCORT VEHICLE MUST PRECEDE OR FOLLOW THE OUTSIZED VEHICLE		
DIMENSIONS AND COMBINATION OF DIMENSIONS OF OUTSIZED VEHICLES TRAVELLING IN CONVOY	TYPE OF ROAD	
	WITH ONE TRAFFIC LANE IN THE DIRECTION TRAVELLED BY THE VEHICLE	WITH MORE THAN ONE TRAFFIC LANE IN THE DIRECTION TRAVELLED BY THE VEHICLE
		
		
A ONLY	PRECEDE	NOT REQUIRED
B ONLY	PRECEDE	FOLLOW
C ONLY	PRECEDE AND FOLLOW	FOLLOW
D OR E ONLY	FOLLOW	FOLLOW
F OR G ONLY	PRECEDE	PRECEDE
A AND D OR E	PRECEDE AND FOLLOW	FOLLOW
A AND F OR G	PRECEDE	PRECEDE
B AND D OR E	PRECEDE AND FOLLOW	FOLLOW
B AND F OR G	PRECEDE	PRECEDE AND FOLLOW
C AND D OR E	PRECEDE AND FOLLOW	FOLLOW
C AND F OR G	PRECEDE AND FOLLOW	PRECEDE AND FOLLOW
D OR E AND F OR G	PRECEDE AND FOLLOW	PRECEDE AND FOLLOW

9. An escort vehicle must:

- (1) have a net mass of less than 3 000 kg;
- (2) be equipped with flares, lamps or *reflectors* visible at a distance of not less than 300 m;
- (3) *be equipped with 2 amber lights, at least 1 m apart, with a range of 360°, or 3 amber lights with the centre light having a range of 360° and the other 2 being flashing lights at least 1 m apart. The lights must operate at a rate of 60 to 90 cycles per minute. The light with a range of 360° must have a lens at least 10 cm in height whose width or diameter at that height is at least 12 cm and must be visible in every direction up to a minimum distance of 300 m. The flashing lights must have a minimum diameter of 17.50 cm and must be visible up to a minimum distance of 300 m from the front and the rear.*

10. *In the case of transport requiring a Class 2 permit and where such transport is carried out on a divided autoroute, the escort vehicle is not required where the vehicle covered by the special permit is equipped with 4 flashing amber lights with a minimum diameter of 17.50 cm, operating at a rate of 60 to 90 cycles per minute and visible up to a minimum distance of 300 m. Those lights must be placed at the widest part of each front and rear extremity of the building, excluding the roof, at least 2 m from the ground. Notwithstanding the foregoing, the front lights may be placed to the rear of the side rear-view mirrors.*

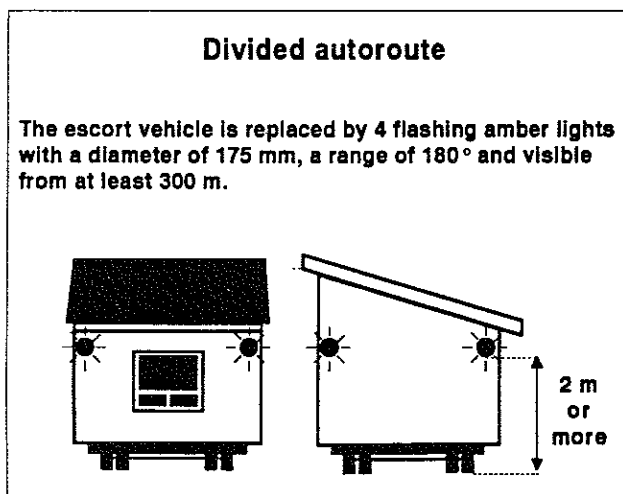

DIVISION II - TRAFFIC RULES

11. A special permit does not authorize travelling:

- (1) at night, for a vehicle or combination of vehicles where, including the load and equipment:**
 - (a) the length exceeds, respectively, 17 m for a single unit road vehicle, 27.50 m for a combination of 2 road vehicles, including a combination of road vehicles consisting of a crane and a trailer, and 30 m for a combination of 3 road vehicles consisting of a tractor, a hauled dolly and a semi-trailer or for a combination of vehicles covered by a Class 2 permit;**
 - (b) the rear overhang is greater than 4 m, except for trees loaded lengthwise and posts;**
 - (c) the width exceeds 3.75 m. Notwithstanding the foregoing, that restriction does not apply if the width does not exceed 4.40 m, provided that the vehicle travels on a divided autoroute or over a maximum distance of 8 km on a road numbered from 100 to 199 to reach a destination. In the case of a Class 2 permit, the width must be measured at the widest part of the building, excluding the roof;**

NIGHT TRAVEL PROHIBITED

WIDTH

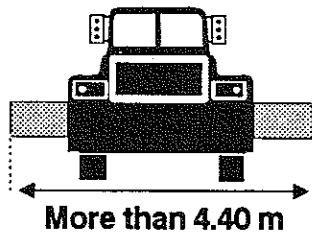
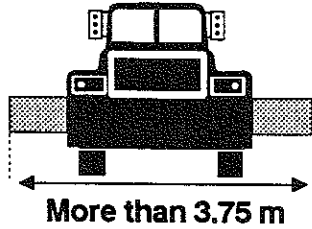

On a divided autoroute and over a maximum distance of 8 km on a two-way road numbered from 100 to 199 to reach a destination.

LENGTH

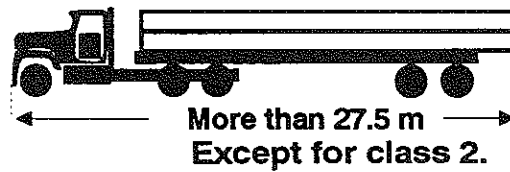

OVERHANG

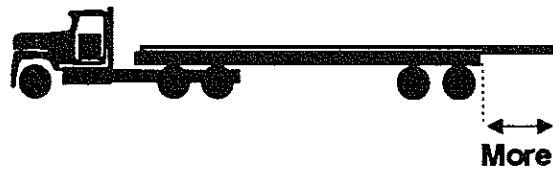

Except for trees loaded lengthwise and wood utility poles

- (2) on Sundays and legal holidays;
- (3) by a vehicle whose total loaded mass or dimensions exceed the limit established for that public highway;

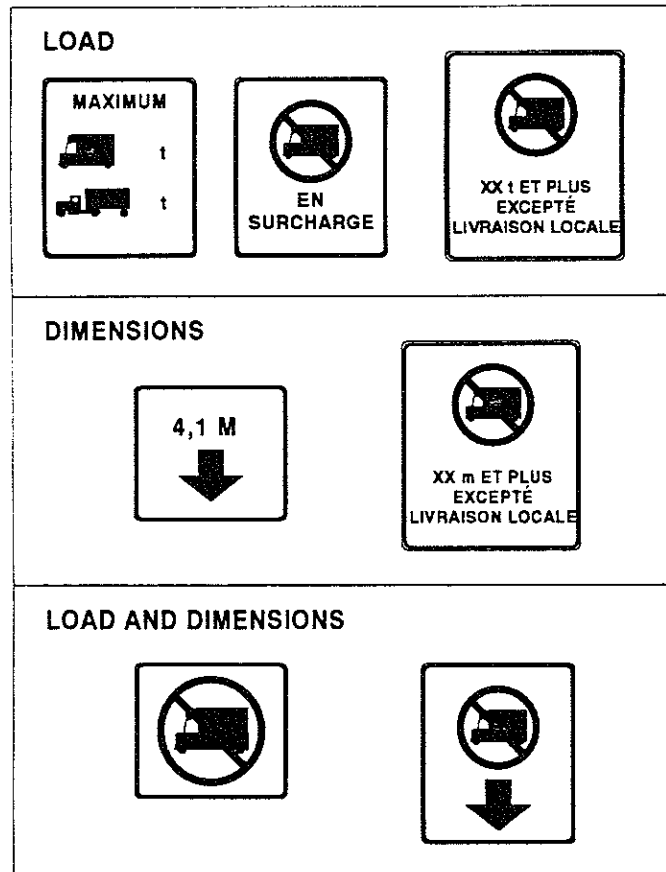

- (4) where the *visibility* does not extend to a distance of 1 km or the roadway is not cleared of snow or ice *in accordance with the maintenance conditions applicable to that highway.*

Notwithstanding the foregoing, the restrictions in subparagraphs 1 and 2 of the first paragraph do not apply to cranes and those in subparagraphs 1, 2 and 4 of the first paragraph do not apply to a Class 4 permit or to snow removal vehicles. The restrictions in subparagraphs 1 to 4 of the first paragraph do not apply to the implementation of emergency measures following a disaster, a derailment or a spill of hazardous substances or in the case of transport covered by a Class 6 or Class 7 permit, provided that a carrier has obtained prior authorization from the Société.

12. A special permit does not authorize travel on the following roadways and at the following times solely for a vehicle or a combination of road vehicles, including the load and equipment, of a width exceeding 3.75 m or of a length exceeding respectively *17 m for a single unit vehicle, 21 m for a crane, 27.50 m for a combination of 2 road vehicles including a combination of road vehicles consisting of a crane and a semi-trailer, and 30 m for a combination of 3 road vehicles consisting of a tractor, a hauled dolly and a semi-trailer or for a combination of vehicles covered by a Class 2 permit or for any vehicle whose rear overhang is more than 4 m:*

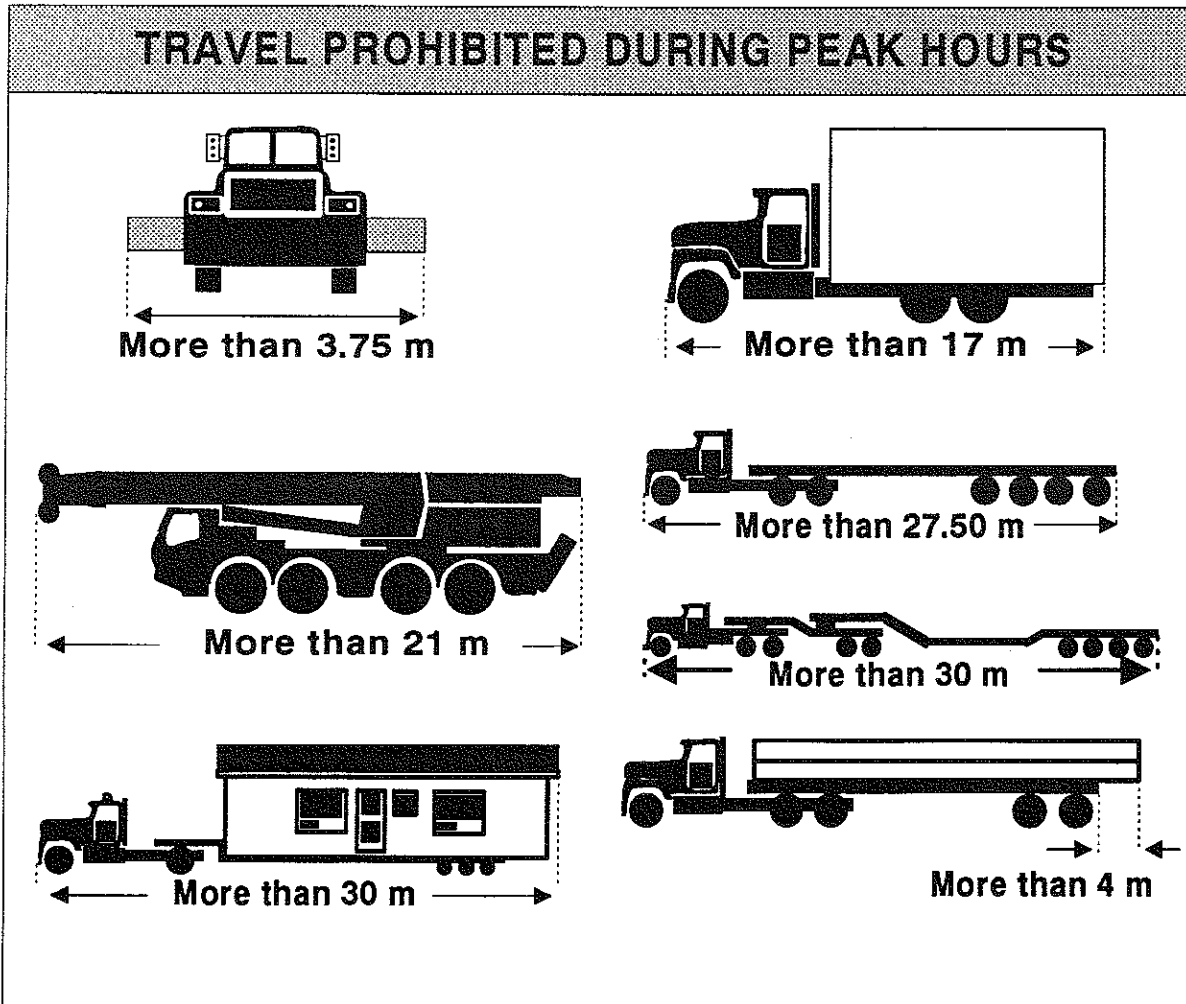

- (1) in the Québec region from 7:30 a.m. to **9:00 a.m.** and from 4:00 p.m. to 5:30 p.m. on:
- the Québec bridge and its approaches;
 - the Pierre-Laporte bridge and its approaches;
 - autoroute 40 between the intersection with autoroute 73 and the intersection with autoroute 440;
 - autoroute 73 between autoroute 20 and Notre-Dame-des-Laurentides;
 - autoroute 440 between Saint-Augustin and Québec;
 - autoroute 540;
- (2) in the Montréal region from 6:30 a.m. to 9:30 a.m. and from 3:30 p.m. to 7:00 p.m. on:
- autoroute 20, between exit 29 and exit 98;
 - autoroute 40 between exit 35 and exit 89;
 - autoroute 25;
 - autoroute 440;
 - autoroute 520;
 - autoroute 640;
 - autoroute 15 between exit 29 and exit 44;
 - autoroute 13;
 - route 132 between autoroute 15 and Boucherville;
 - route 138 between Honoré-Mercier bridge and autoroute 20;
 - the Champlain bridge and its approaches;
 - the Honoré-Mercier bridge and its approaches;
 - the Jacques-Cartier bridge and its approaches.

The travel restrictions in subparagraphs 1 and 2 do not apply on Saturday.

In the case of a Class 2 permit, the width must be measured at the widest part of the building, excluding the roof.

13. *The escort vehicles required to travel under a special permit may escort a maximum of 2 oversized vehicles travelling in convoy, except for a Class 7 permit, in which case travelling in convoy must be expressly authorized.*

The drivers of vehicles travelling in convoy must, where applicable, allow passing every 15 minutes or at the first place where it can be done safely.

From 28 February 1994, the last vehicle in the convoy must be equipped with a board or hard surface complying with the standards in Schedule 5.

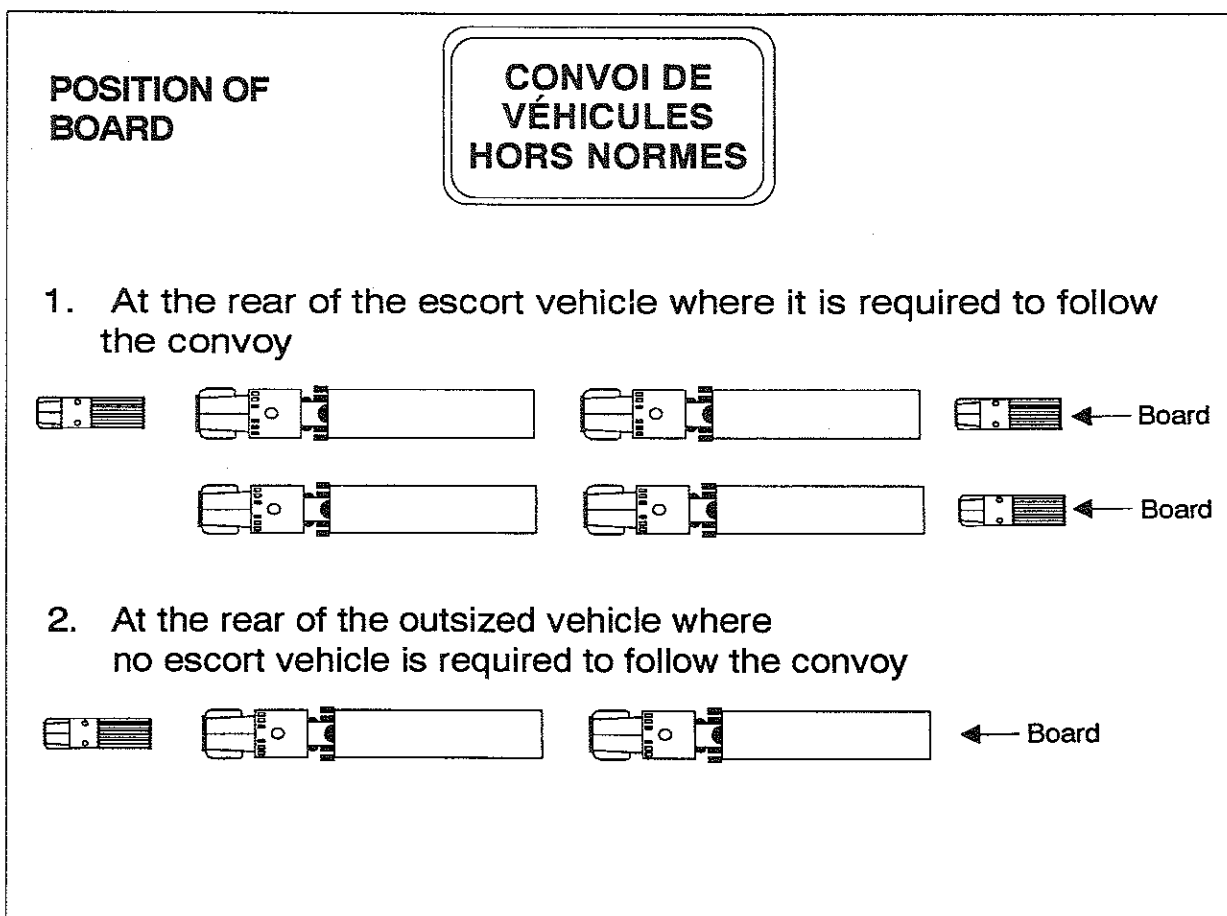

14. *The driver of a vehicle for which a special permit has been issued must respect the requirements prescribed in subparagraphs 2 to 9 and 12 of the first paragraph of section 5 and those prescribed in section 11;*
- 14.1 *The driver of a road vehicle or combination of road vehicles authorized by a Class 6 permit to travel on the network of autoroutes referred to in Schedule 4 must travel in a centre lane of a bridge where that highway has more than 2 traffic lanes in the same direction.*
15. *The driver of an escort vehicle must:*
- (1) *be able to communicate, using a radio system, with the occupant of the escorted vehicle and, where applicable, with the occupant of the police vehicle and the occupant of another escort vehicle;*
 - (2) *travel with the headlights and the amber lights turned on;*
 - (3) *have in his possession a document containing the information referred to in paragraphs 16, 17 and 20 of section 4.*

Where only one escort vehicle is required, the driver of the escort vehicle must:

- (1) *if the escorted vehicle is oversized with respect to width, follow the escorted vehicle on a road that has more than one traffic lane in the direction travelled by the vehicle and precede it on a road that has only one traffic lane in the direction travelled by the vehicle;*
- (2) *if the escorted vehicle is oversized with respect to height or the front overhang, precede the escorted vehicle;*
- (3) *if the escorted vehicle is oversized with respect to length or the rear overhang, follow the escorted vehicle;*
- (4) *if 2 escorted vehicles travel in convoy, follow or precede the convoy in compliance with the rules referred to in subparagraphs 1, 2 and 3 of this paragraph.*

Where 2 escort vehicles are required, the driver of one must precede the escorted vehicle or the convoy and the driver of the other must follow the escorted vehicle or the convoy.

In all cases, the driver of the escort vehicle must keep a distance of not less than 100 m nor more than 300 m between his vehicle and the escorted vehicle or the convoy.

CHAPTER V
FEEs EXIGIBLE FOR A SPECIAL PERMIT

16. *The fees exigible for a specific permit are the following:*

- (1) *in the case of a Class 1, Class 2 or Class 3 permit, \$105;*
- (2) *in the case of a Class 4, Class 5, Class 6 or Class 7 permit, \$230;*
- (3) *in the case of a Class 6 permit issued for travel on a bridge where a sign prohibits travel by oversized vehicles, \$30 where the permit is issued to one of the following persons;*
 - (a) *to the holder of a Class 4 or Class 5 general permit;*
 - (b) *to the holder of a Class 6 general permit authorizing travel on the network of autoroutes referred to in Schedule 4 or on all public highways.*

The date of expiry of a Class 6 permit for travel on a bridge on which signs prohibit travel by oversized vehicles must be identical or prior to the date of expiry of the general permit referred to in clause (a) or (b).

17. *The annual fees exigible for a general permit are the following:*

- (1) *in the case of a Class 1, Class 2 or Class 3 permit, \$260;*
- (2) *in the case of a Class 4, Class 5, Class 6 or Class 7 permit, \$600;*
- (3) *in the case of a Class 6 permit issued for travel on a bridge where a sign prohibits travel by oversized vehicles, \$100 where the permit is issued to one of the following persons:*
 - (a) *to the holder of a Class 4 or Class 5 general permit;*
 - (b) *to the holder of a Class 6 general permit authorizing travel on the network of autoroutes referred to in Schedule 4 or on all public highways.*

The period of validity of the general permit referred to in clause (a) or (b) must be of the same length as or longer than the period of validity of the Class 6 permit for travel on a bridge where a sign prohibits travel by oversized vehicles and the date of expiry of the permit applied for must be identical or prior to the date of expiry of the general permit referred to in clause (a) or (b).

17.1 *The fees exigible for a general permit covering a period of less than 12 months are determined by adding to the fees exigible for a specific permit the result obtained by multiplying the number of months to be authorized by the following amounts:*

- (1) *\$12.92 for a Class 1, Class 2 or Class 3 permit;*
- (2) *\$30.83 for a Class 4, Class 5, Class 6 or Class 7 permit;*
- (3) *\$5.83 for a Class 6 permit issued to travel on a bridge where a sign prohibits travel by oversized vehicles, where that permit is issued to one of the following persons:*
 - (a) *to the holder of a Class 4 or Class 5 general permit;*
 - (b) *to the holder of a Class 6 general permit authorizing travel on the network of autoroutes referred to in Schedule 4 or on all public highways.*

In the case of a Class 5 or Class 6 permit, the fees exigible for a general permit covering a period shorter than one year are equal to the annual fees where the applicant applies for a permit of a duration equal to or exceeding 9 months.

18. The fees exigible for a permit belonging to more than one class shall be the highest amount of the exigible fees among all of the classes to which it belongs.

An exigible amount calculated under this Regulation must be reduced to the nearest dollar where it contains a fraction of a dollar less than \$0.50; it must be increased to the nearest dollar where it contains a fraction of a dollar equal to or greater than \$0.50.

To be eligible for the fees provided for in subparagraph 3 of the first paragraph of each of sections 16, 17 and 17.1, the applicant must indicate to the Société the number of the permit he holds at the time of the application.

FEES

CLASS	SPE- CIFIC	1 month	2 months	3 months	4 months	5 months	6 months	7 months	8 months	9 months	10 months	11 months	12 months
1, 2, 3	105 \$	118 \$	131 \$	144 \$	157 \$	170 \$	183 \$	195 \$	208 \$	221 \$	234 \$	247 \$	260 \$
4	230 \$	261 \$	292 \$	322 \$	353 \$	384 \$	415 \$	446 \$	477 \$	507 \$	538 \$	569 \$	600 \$
5, 6	230 \$	261 \$	292 \$	322 \$	353 \$	384 \$	415 \$	446 \$	477 \$	600 \$	600 \$	600 \$	600 \$
7	230 \$	261 \$	292 \$	322 \$	353 \$	384 \$	415 \$	446 \$	477 \$	507 \$	538 \$	569 \$	600 \$
6 (restricted bridge)	30 \$	36 \$	42 \$	47 \$	53 \$	59 \$	65 \$	71 \$	77 \$	100 \$	100 \$	100 \$	100 \$

**CHAPTER VI
OFFENCES**

19. A violation of sections 5, 7 to 9 and 11 to 15 constitutes an offence.

**CHAPTER VII
TRANSITIONAL AND FINAL**

20. This Regulation replaces the Directive sur les permis spéciaux de circulation (R.R.Q., 1981, c. C-24, r. 12) and the Regulation respecting the cost of special permits authorizing vehicles with oversized or overweight loads to drive on public highways (R.R.Q., 1981, c. C-24, r. 11).
21. A special travel permit issued before 1 November 1990 is valid until the date of its expiry or until 1 April 1991 where it authorizes the circulation of farm machinery or where it authorizes the transport of a divisible load with a modified vehicle or with a vehicle the configuration of those axles is not prescribed in the Regulation.
22. This Regulation comes into force on 8 November 1990.

This is the date on which the Regulation respecting special permits (O.C. 1444-90) came into effect. The Regulation to amend the Regulation respecting special permits came into force 24 January 1994 (see Introduction, page 1 of this guide).

SCHEDULE 1

(s. 2, subpars. 4, 5 and 6)

DIVISION 1 - DETERMINATION OF THE MAXIMUM AXLE LOAD

1. The maximum axle load is the lowest of the following load limits:

(1) For a single axle:

- (a) the sum of the load limits specified by the tire manufacturer;
- (b) in the case of an axle controlled by the steering wheel, the axle load limit indicated by the vehicle manufacturer;
- (c) the limits indicated in Table 1 with respect to tire section width.

(2) *For a tandem, triple or quadruple axle or for a combination of 2, 3 or 4 axles:*

- (a) *the sum of the load limits specified by the tire manufacturer,*
- (b) *in the case of axles controlled by the steering wheel, the load limit specified by the manufacturer of the vehicle;*

- (c) *the limits indicated in Tables 2, 3 and 4 with respect to tire section width and axle spacing less, where applicable, 3 000 kg for any group of axles that does not have all the characteristics of a tandem, triple or quadruple axle;*

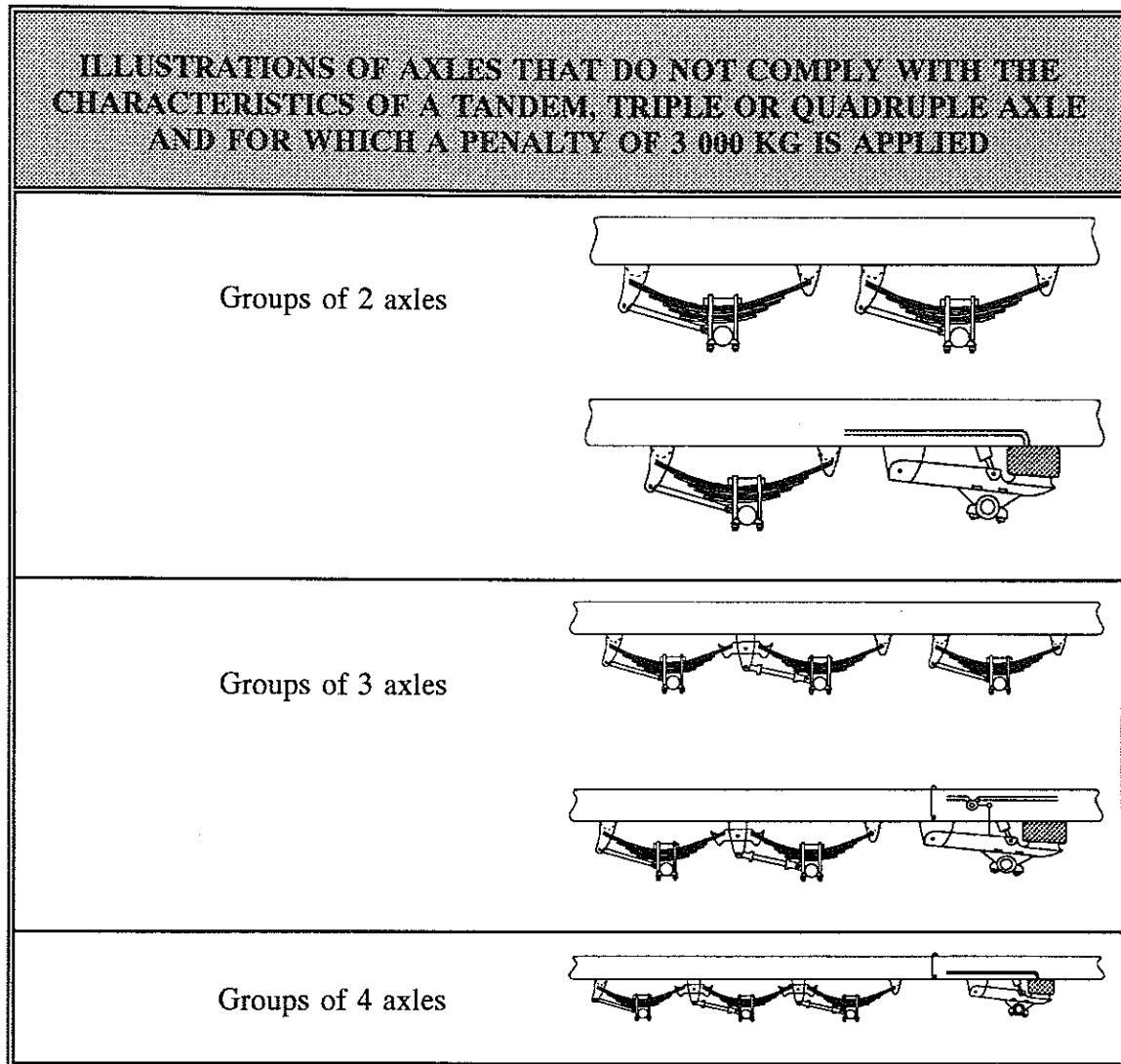

- (d) *20 000 kg for the rear tandem axle of a tractor in the case of a combination of road vehicles consisting of a tractor, a hauled dolly and a semi-trailer and, where applicable, 20 000 kg for the tandem axle of a hauled dolly.*

DIVISION 2 - DETERMINATION OF THE TOTAL LOADED MASS

2. The maximum total loaded mass of a road vehicle or of a combination or road vehicles is the lowest of the following load limits:
- (1) *for a road vehicle, the sum of the axle loads established in accordance with section 1 of this Schedule, without exceeding:*
 - (a) *24 000 kg for a vehicle equipped with 2 axles;*
 - (b) *36 000 kg for a vehicle equipped with 3 axles, including 2 located at the rear of the vehicle, where the minimum space between the centre of the front axle and the centre of the first axle in the group of axles located at the rear of the vehicle is 4.50 m;*
 - (2) *for a combination of road vehicles equipped with not more than 4 axles, the sum of the axle loads established in accordance with section 1 of this Schedule, without exceeding 51 000 kg for a combination of road vehicles where the minimum space between the centre of the rear single axle of the tractor or the centre of the last axle of its tandem axle and the centre of the single axle or of the first axle in the group of axles located under the semi-trailer is 8.50 m;*
 - (3) *for a combination of road vehicles equipped with 5 axles, including 2 located under the semi-trailer, the sum of the axle loads established in accordance with section 1 of this Schedule, without exceeding 36 000 kg for a tractor and 66 000 kg for a combination of road vehicles where the minimum space between the centre of the last axle of the tandem axle of the tractor and the centre of the first axle in the group of axles located under the semi-trailer is 8.50 m;*
 - (4) *for a combination of road vehicles equipped with 6 axles, including 3 located under the semi-trailer, the sum of the axle loads established in accordance with section 1 of this Schedule, without exceeding 36 000 kg for a tractor and 72 000 kg for a combination of road vehicles where the minimum space between the centre of the last axle of the tandem axle of the tractor and the centre of the first axle in the group of axles located under the semi-trailer is 8.50 m;*

- (5) *for a combination of road vehicles equipped with 7 axles, including 4 located under the semi-trailer, the sum of the axle loads established in accordance with section 1 of this Schedule, without exceeding 36 000 kg for a tractor and 74 000 kg for a combination of road vehicles where the minimum space between the centre of the last axle of the tandem axle of the tractor and the centre of the first axle in the group of axles located under the semi-trailer is 10 m;*
- (6) *until 31 December 1997, for a combination of road vehicles equipped with 7 or 8 axles, consisting of a tractor equipped with 3 axles, of which 2 form a tandem axle, a hauled dolly equipped with a single axle and a semi-trailer equipped with 3 or 4 axles, the sum of the axle loads established in accordance with section 1 of this Schedule, without exceeding 29 000 kg for a tractor, 42 000 kg for a combination consisting of a tractor and a hauled dolly where the minimum space between the centre of the last axle of the tandem axle of the tractor and the centre of the single axle of the hauled dolly is 2.40 m, and 76 000 kg for a combination of road vehicles where the minimum space between the centre of the single axle of the hauled dolly and the centre of the first axle in the group of axles located under the semi-trailer is 10 m;*
- (7) *until 31 December 1997, for a combination of road vehicles equipped with 8 or 9 axles, consisting of a tractor equipped with 3 axles, of which 2 form a tandem axle, a hauled dolly equipped with a tandem axle and a semi-trailer equipped with 3 or 4 axles, the sum of the axle loads established in accordance with section 1 of this Schedule, without exceeding 26 000 kg for a tractor, 45 000 kg for a combination consisting of a tractor and a hauled dolly where the minimum space between the centre of the last axle of the tandem axle of the tractor and the centre of the first axle of the tandem axle of the hauled dolly is 2.40 m, and 79 000 kg for a combination of road vehicles where the minimum space between the centre of the last axle of the tandem axle of the hauled dolly and the centre of the first axle in the group of axles located under the semi-trailer is 10 m;*

The first paragraph applies with the following adaptation to establish the maximum total loaded mass of the road vehicle or the combination or road vehicles where the spaces between the axles are less than those prescribed:

the limit of 36 000 kg prescribed in clause (b) of subparagraph 1 of the first paragraph and the limits of 42 000 kg, 45 000 kg, 51 000 kg, 66 000 kg, 72 000 kg, 74 000 kg, 76 000 kg and 79 000 kg shall be reduced by 750 kg per complete segment of 0.30 m below the space prescribed.

**EXAMPLES OF
THE DETERMINATION OF THE MAXIMUM AXLE LOAD AND OF
THE GROSS VEHICLE WEIGHT (TOTAL LOADED MASS)
(Schedule 1, Divisions 1 and 2)**

EXAMPLE 1 :

Combination of vehicles consisting of a tractor and a semi-trailer equipped with 4 axles

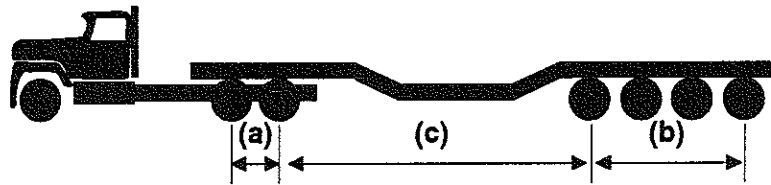

DETERMINATION OF THE MAXIMUM AXLE LOAD

Step 1 : Note the capacity of the axle controlled by the steering wheel (GAWR);

Ex. : 6 350 kg _____ _____

Step 2 : Note the sum of the load limits specified by the tire manufacturer;

Ex. : 6 400 kg 28 500 kg 42 000 kg

Step 3 : Measure the axle spread (a) and (b) as illustrated;

Ex. : (a) = 1.52 m (b) = 4.56 m

Step 4 : a) Determine the load limits according to Tables 1, 2, 3 and 4 of the guide. The load is a function of values (a) and (b) entered in the preceding step and the tire width (ex.: tractor tires 315/80R.22.5 = 315 mm, semi-trailer tires 12R.22.5 = 304 mm);

Ex. : 9 500 kg 28 000 kg 36 000 kg

b) Verify whether the axle groups comply with the characteristics of section 0.1. Deduct 3 000 kg from the load limits determined in 4 (a) for each group of axles that do not comply with the characteristics.

Ex. : — yes no

9 500 kg 28 000 kg 33 000 kg (36 000 - 3 000)

Step 5 : For each axle group of axles, the maximum axle load authorized is the lesser of the limits entered in Steps 1, 2 and 4;

Ex. : 6 350 kg 28 000 kg 33 000 kg

DETERMINATION OF THE GROSS VEHICLE WEIGHT

Step 6 : Measure interaxle spacing (c) as illustrated;

Ex. : 9.65 m = (c);

Step 7 Determine the minimum interaxle spacing required under Division 2 for the combination of vehicles;

Ex. : minimum interaxle spacing = 10.00 m;

Step 8 : Enter the maximum gross vehicle weight for the combination of vehicles as specified in Division 2;

Ex. : maximum gross vehicle weight = 74 000 kg;

Step 9 : Add the axle load limits entered in Step 5;

Ex. : 6 350 kg + 28 000 kg + 33 000 kg = 67 350 kg

Step 10 : If interaxle spacing (c) is less than the minimum interaxle spacing entered in Step 7, deduct from the gross vehicle weight in Step 8, 750 kg per complete segment of 0.30 m lacking;

Ex. : 74 000 kg minus (750 kg X 1 segment of 0.30 m)
 corrected maximum gross vehicle weight = 73 250 kg

Step 11 : The authorized maximum gross vehicle weight is the lesser of those determined in Steps 8, 9 and 10;

Ex. : authorized maximum gross vehicle weight = 67 350 kg

Step 12 : Check Division 2 of Schedule 1 for maximum load allowed for the tractor.

Ex. : tractor load = 36 000 kg

RESULTS OF EXAMPLE 1

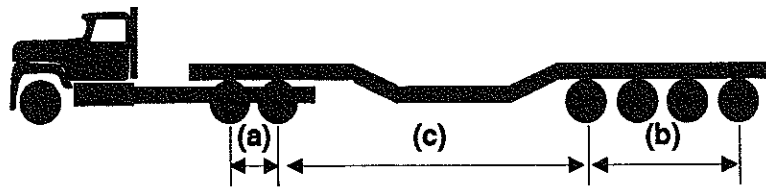

Maximum axle load authorized 6 350 kg 28 000 kg 33 000 kg

Gross vehicle weight authorized _____
67 350 kg

Authorized tractor load _____
36 000 kg

**EXAMPLES OF
 DETERMINATION OF THE MAXIMUM AXLE LOAD AND OF THE GROSS
 VEHICLE WEIGHT (TOTAL LOADED MASS)**

(Schedule 1, Divisions 1 and 2)

EXAMPLE 2 :

Combination of vehicles consisting of a tractor, a jeep dolly (hauled dolly) and a semi-trailer

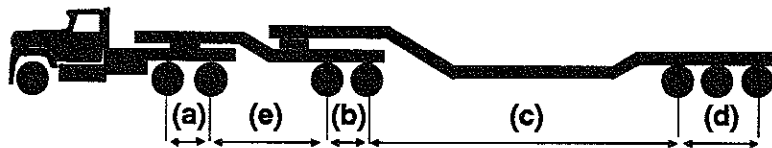

DETERMINATION OF THE MAXIMUM AXLE LOAD

Step 1 : Note the capacity of the axle controlled by the steering wheel (GAWR);

Ex. : 6 350 kg _____

Step 2 : Note the sum of the load limits specified by the tire manufacturer;

Ex. : 6 400 kg 28 500 kg 25 000 kg 37 000 kg

Step 3 : Measure the axle spread (a), (b) and (d) as illustrated;

Ex. : (a) = 1.52 m (b) = 1.52 m
 (d) = 3.04 m

Step 4 : a) Determine the load limits according to Tables 1, 2, 3 and 4 of the guide. The load is a function of values (a), (b) and (d) entered in the preceding step and the tire width (ex.: tractor tires 315/80 R22.5 = 315 mm, jeep dolly and semi-trailer tires 12R22,5 = 304 mm);

Ex. : 9 500 kg 28 000 kg 28 000 kg 34 000 kg

b) Verify whether the axle groups comply with the characteristics of section 0.1. Deduct 3 000 kg from the load limits determined in 4 (a) for each group of axles that do not comply with the characteristics.

Ex. : — yes yes yes

9 500 kg 28 000 kg 28 000 kg 34 000 kg

Step 5 : For each axle or group of axles, the maximum axle load authorized is the lesser of the limits entered in Steps 1, 2 and 4, without exceeding 20 000 kg for the tandem axles of the tractor and the jeep dolly (Schedule 1, Division 1, section 1);

Ex. : 6 350 kg 20 000 kg 20 000 kg 34 000 kg

DETERMINATION OF THE GROSS VEHICLE WEIGHT

Step 6 : Measure the interaxle spacing (c) and (e) as illustrated;

Ex. : (c) = 9.65 m (e) = 2.40 m;

Step 7 : Determine the minimum interaxle spacing required under Division 2 for the combination of vehicles;

Ex. : (c) = 10.00 m;

Ex. : (e) = 2.40 m;

Step 8 : Enter the maximum gross vehicle weight for the combination of vehicles as specified in Division 2;

Ex. : maximum gross vehicle weight = 79 000 kg;

- Step 9 :** Add the axle load limits entered in Step 5;
 Ex.: $6\ 350\text{ kg} + 20\ 000\text{ kg} + 20\ 000\text{ kg} + 34\ 000\text{ kg} = 82\ 350\text{ kg}$
- Step 10 :** If interaxle spacing (c) or (e) is less than the minimum interaxle spacing entered in Step 7, deduct from the gross vehicle weight in Step 8, 750 kg per complete segment of 0.30 m lacking;
 Ex. : $79\ 000\text{ kg}$ minus (750 kg X 1 segment of 0.30 m)
 corrected maximum gross vehicle weight = $78\ 250\text{ kg}$
- Step 11 :** The authorized maximum gross vehicle weight is the lesser of those determined in Steps 8, 9 and 10;
 Ex. : authorized maximum gross vehicle weight = $78\ 250\text{ kg}$
- Step 12 :** Check Division 2 of Schedule 1 for the maximum loads allowed for the tractor and for a combination consisting of a tractor and a jeep dolly.
 Ex. : tractor load = $26\ 000\text{ kg}$
 load for combination of tractor and jeep dolly = $45\ 000\text{ kg}$

RÉSULTS OF EXAMPLE 2

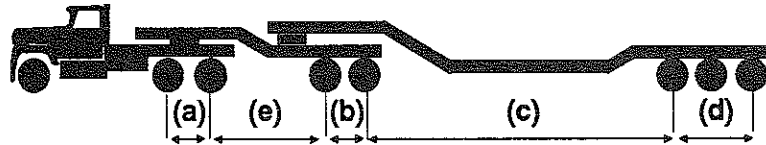

Maximum axle load				
authorized	<u>6 350 kg</u>	<u>20 000 kg</u>	<u>20 000 kg</u>	<u>34 000 kg</u>
Gross vehicle weight	_____			
authorized	78 250 kg			
Authorized tractor	_____			
load	26 000 kg			
Authorized load for	_____			
combination of	45 000 kg			
tractor and				
jeep dolly				

Table 1
SINGLE AXLE LOAD LIMITS

<i>Classification by tire width (mm)</i>	<i>S : Single D : Dual</i>	<i>Permitted load in kilograms</i>
190-202	S D	4 500 8 000
203-253	S D	6 000 11 000
254-303	S D	8 500 14 500
304-354	S D	9 500 15 000
355-405	S D	10 500 15 000
406-456	S D	11 500 15 000
457-507	S	12 500
508-557	S	13 000
558-608	S	13 750
609 and over	S	14 500

PROVISIONAL EDITION
GUIDE TO THE REGULATION RESPECTING SPECIAL PERMITS

Table 2
TANDEM AXLE LOAD LIMITS

<i>Classification by tire width (mm)</i>		<i>Permitted load in kilograms Spacing between the axles (cm)</i>						
		<i>100 to 124</i>	<i>125 to 129</i>	<i>130 to 139</i>	<i>140 to 149</i>	<i>150 to 159</i>	<i>160 to 175</i>	<i>176 and over</i>
190-202	<i>S</i>	9 000	9 000	9 000	9 000	9 000	9 000	9 000
	<i>D</i>	16 000	16 000	16 000	16 000	16 000	16 000	16 000
203-253	<i>S</i>	11 500	11 500	11 500	11 500	11 500	11 500	11 500
	<i>D</i>	22 000	22 000	22 000	22 000	22 000	22 000	22 000
254-303	<i>S</i>	13 250	13 250	13 250	13 250	13 250	13 250	13 250
	<i>D</i>	25 000	25 000	25 000	25 000	25 000	25 000	25 000
304-354	<i>S</i>	15 000	15 000	15 000	15 000	15 000	15 000	15 000
	<i>D</i>	26 500	27 500	28 000	28 000	28 000	28 000	28 000
355-405	<i>S</i>	16 500	16 500	16 500	16 500	16 500	16 500	16 500
	<i>D</i>	26 500	27 500	29 000	29 500	30 000	30 000	30 000
406-456	<i>S</i>	18 000	18 000	18 000	18 000	18 000	18 000	18 000
	<i>D</i>	26 500	27 500	29 000	29 500	30 000	30 000	30 000
457-507	<i>S</i>	19 500	19 500	19 500	19 500	19 500	19 500	19 500
508-557	<i>S</i>	21 000	21 000	21 000	21 000	21 000	21 000	21 000
558-608	<i>S</i>	22 500	22 500	22 500	22 500	22 500	22 500	22 500
609 and over	<i>S</i>	24 000	24 000	24 000	24 000	24 000	24 000	24 000

Table 3
TRIPLE AXLE LOAD LIMITS

		Permitted load in kilograms Spacing between the most distant axles (cm)						
		200 to 249	250 to 259	260 to 279	280 to 299	300 to 319	320 to 349	350 and over
190-202	S	11 250	11 250	11 250	11 250	11 250	11 250	11 250
	D	22 000	22 000	22 000	22 000	22 000	22 000	22 000
203-253	S	13 500	13 500	13 500	13 500	13 500	13 500	13 500
	D	26 000	26 000	26 000	26 000	26 000	26 000	26 000
254-303	S	15 750	15 750	15 750	15 750	15 750	15 750	15 750
	D	30 000	30 000	30 000	30 000	30 000	30 000	30 000
304-354	S	18 000	18 000	18 000	18 000	18 000	18 000	18 000
	D	30 000	31 500	33 000	33 500	34 000	34 000	34 000
355-405	S	20 000	20 000	20 000	20 000	20 000	20 000	20 000
	D	30 000	31 500	33 000	33 500	34 500	35 000	36 000
406-456	S	21 750	21 750	21 750	21 750	21 750	21 750	21 750
	D	30 000	31 500	33 000	33 500	34 500	35 000	36 000
457-507	S	23 500	23 500	23 500	23 500	23 500	23 500	23 500
508-557	S	25 000	25 000	25 000	25 000	25 000	25 000	25 000
558-608	S	26 500	26 500	26 500	26 500	26 500	26 500	26 500
609 and over	S	28 000	28 000	28 000	28 000	28 000	28 000	28 000

PROVISIONAL EDITION
 GUIDE TO THE REGULATION RESPECTING SPECIAL PERMITS

Table 4
QUADRUPLE AXLE LOAD LIMITS

<i>Classification by tire width (mm)</i>		<i>Permitted load in kilograms</i>		
		<i>Spacing between the most distant axles (cm)</i>		
		<i>350 to 399</i>	<i>400 to 459</i>	<i>460 and over</i>
<i>199-202</i>	<i>S</i>	<i>12 850</i>	<i>12 850</i>	<i>12 850</i>
	<i>D</i>	<i>24 000</i>	<i>24 000</i>	<i>24 000</i>
<i>203-253</i>	<i>S</i>	<i>14 500</i>	<i>14 500</i>	<i>14 500</i>
	<i>D</i>	<i>28 000</i>	<i>28 000</i>	<i>28 000</i>
<i>254-303</i>	<i>S</i>	<i>16 250</i>	<i>16 250</i>	<i>16 250</i>
	<i>D</i>	<i>32 000</i>	<i>32 000</i>	<i>32 000</i>
<i>304-354</i>	<i>S</i>	<i>18 500</i>	<i>18 500</i>	<i>18 500</i>
	<i>D</i>	<i>36 000</i>	<i>36 000</i>	<i>36 000</i>
<i>355-405</i>	<i>S</i>	<i>20 500</i>	<i>20 500</i>	<i>20 500</i>
	<i>D</i>	<i>36 000</i>	<i>37 000</i>	<i>38 000</i>
<i>406-456</i>	<i>S</i>	<i>22 750</i>	<i>22 750</i>	<i>22 750</i>
	<i>D</i>	<i>36 000</i>	<i>37 000</i>	<i>38 000</i>
<i>457-507</i>	<i>S</i>	<i>24 500</i>	<i>24 500</i>	<i>24 500</i>
<i>508-557</i>	<i>S</i>	<i>26 000</i>	<i>26 000</i>	<i>26 000</i>
<i>558-608</i>	<i>S</i>	<i>27 500</i>	<i>27 500</i>	<i>27 500</i>
<i>609 and over</i>	<i>S</i>	<i>28 500</i>	<i>28 500</i>	<i>28 500</i>

DIVISION 3 - THAW

3. *During a thaw, the maximum axle load of a combination of 3 road vehicles consisting of a tractor, a hauled dolly and a semi-trailer is the lesser of the following limits:*
- (1) *the limit established in accordance with section 1 of this Schedule;*
 - (2) *the limit indicated in Table 5, or 9 000 kg for a front axle controlled by the steering wheel.*
4. *During a thaw, the maximum total loaded mass of a combination of 3 road vehicles consisting of a tractor, a hauled dolly and a semi-trailer is the lesser of the following limits:*
- (1) *the limit established in accordance with section 2 of this Schedule;*
 - (2) *the limit obtained by adding the axle loads established in accordance with section 3 of this Schedule;*

TABLE 5
AXLE LOAD LIMITS DURING A THAW

<i>Axle category</i>	<i>Space between the most distant axles (cm)</i>	<i>Tires S1 : Single D1 : Dual</i>	<i>Permitted load in kilograms</i>
<i>Single</i>	---	<i>S</i>	7 000
	---	<i>D</i>	8 000
<i>Tandem</i>	<i>100 to 149</i>	<i>S</i>	12 500
		<i>D</i>	14 500
	<i>150 to 179</i>	<i>S</i>	13 000
		<i>D</i>	15 000
	<i>180 to 239</i>	<i>S</i>	13 500
		<i>D</i>	15 500
<i>Triple</i>	<i>240 à 299</i>	<i>S</i>	17 000
		<i>D</i>	20 000
	<i>300 à 419</i>	<i>S</i>	19 500
		<i>D</i>	22 500
	<i>420 à 479</i>	<i>S</i>	20 000
		<i>D</i>	23 000
<i>single axle at the rear of a tandem</i>	<i>240 et plus</i>	<i>S</i>	17 000
		<i>D</i>	20 000
<i>4 axles</i>	<i>360 à 419</i>	<i>S</i>	20 000
		<i>D</i>	24 000
	<i>420 à 479</i>	<i>S</i>	22 000
		<i>D</i>	26 000
	<i>480 et plus</i>	<i>S</i>	23 500
		<i>D</i>	27 500

SCHEDULE 2
(s. 7, 1st par., subpar. 3)

WARNING SIGNAL WITH A "D"

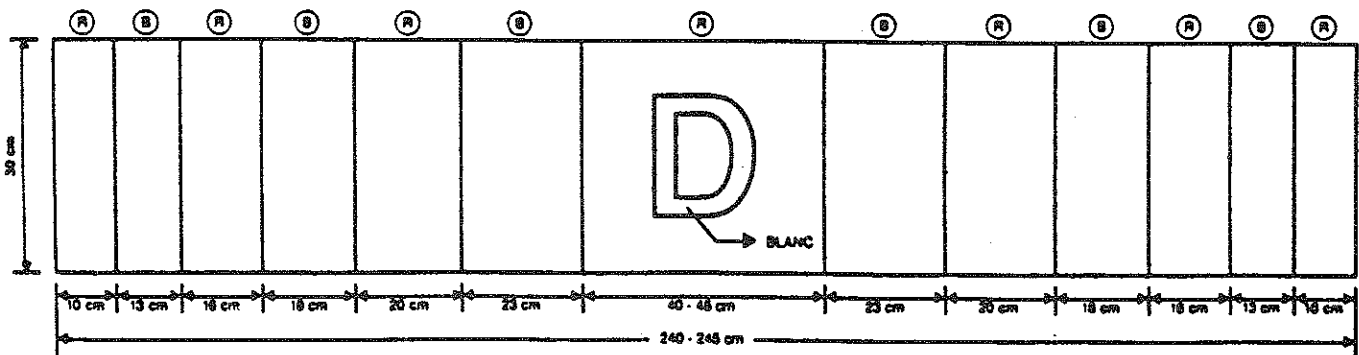

Panneau ou surface rigide: 240 - 245 cm x 30 cm

Dimensions des bandes: conformes au plan

Lettre "D": 20 cm de hauteur et de série E

B: Couleur blanche obtenue à partir d'une pellicule conforme au grade 2 de la norme du Bureau de normalisation du Québec portant le numéro BNQ-6830-101.

R: Couleur rouge obtenue à partir d'une peinture transparente rouge pour signal d'arrêt.

Board or rigid surface :	240 - 245 cm x 30 cm.	B :	White color obtained from a Grade 2 film BNQ-6830-101, in conformity with the standards of the Bureau de Normalisation du Québec.
Dimensions of stripes :	According to plan.	R :	Red color obtained from red transparent paint used for stop signs.
Letter "D" :	20 cm in height - E Series.		

SCHEDULE 3
(s. 5, 1st par., subpar. 9)

ADDITIONAL CONDITIONS

On bridges

- A- *Must travel without sudden braking.*
- B- *Must travel alone on a bridge.*
- C- *Must travel alone and in the exact centre of a bridge with only one traffic lane in the direction travelled by the oversized vehicle.*
- D- *Must travel alone by straddling both lanes in the direction travelled by the oversized vehicle or must travel alone on 2 lanes by straddling the 2 far right lanes on a bridge with more than 2 traffic lanes in the direction travelled by the oversized vehicle.*
- E- *Must travel alone and in the exact centre of a bridge where a sign prohibits travel by oversized vehicles.*
- F- *Must travel on a centre lane of a bridge where the highway has more than 2 traffic lanes in the same direction.*
- G- *Maximum speed of 10 km/h on bridges.*

General

- 1- *Must be escorted by a marked police emergency vehicle.*
- 2- *Departure time must be determined in consultation with a member of the police force in a position of authority.*
- 3- *Night travel authorized.*
- 4- *Night travel only.*
- 5- *Travel authorized on Sundays and legal holidays.*
- 6- *Travel prohibited during a thaw, except where emergency measures are implemented following a disaster, a derailment or a spill of hazardous substances.*
- 7- *Must travel on the far right of the roadway.*

- H-** *Maximum speed of 25 km/h on bridges.*
- I-** *Maximum speed of 40 km/h on bridges.*
- J-** *Maximum speed of 25 km/h on a bridge where a sign prohibits travel by oversized vehicles.*
- K-** *Must install, at the rear of the oversized vehicle, a board or hard surface complying with Schedule 6 of this Regulation.*
- L-** *Must have, in accordance with Schedule 7 of this Regulation, in front of the oversized vehicle, an escort vehicle equipped with a "traffic control person ahead" sign complying with Schedule T2-2 of the Regulation respecting traffic control devices, made by the Order of the Minister of Transport dated 24 November 1989 and amended by the regulations made by Minister's orders dated 31 October 1991 and 15 December 1991, and mounted in accordance with sections 24 and 25 of that Regulation, adapted as required, and a traffic control person where an interruption of traffic is required to enable the oversized vehicle to cross the bridge safely, alone and in the exact centre. That escort vehicle may be used in accordance with Schedule 8 of this Regulation, where the driver of the escort vehicle may warn the driver of the oversized vehicle that the latter may cross the bridge alone and in the centre without an interruption of traffic.*
- M-** *Must install, in accordance with Schedule 7 or 8 of this Regulation, at the rear of the oversized vehicle, a signal arrow light complying with section 180 of the Regulation respecting traffic control devices.*
- 8-** *Must travel with an additional front escort vehicle equipped with a signal arrow light complying with section 180 of the Regulation respecting traffic control devices and used in accordance with Schedule 12 of this Regulation.*
- 9-** *Authorized departure time specified on the permit.*
- 10-** *Time when travel is prohibited as specified on the permit.*
- 11-** *Traffic must be interrupted before the oversized vehicle travels on the roads specified on the permit.*
- 12-** *Must notify the person in charge of the road network or bridge specified on the permit at least 48 hours before the departure of the oversized vehicle.*
- 13-** *Must move the load to the right side of the vehicle.*

- N-** *Must travel with a rear escort vehicle, equipped with a signal arrow light complying with section 180 of the Regulation respecting traffic control devices and used in accordance with Schedule 7 or 8 of this Regulation.*
- O-** *Must travel with 2 rear escort vehicles, each one with a signal arrow light complying with section 180 of the Regulation respecting traffic control devices and used in accordance with Schedule 9 or 10 of this Regulation. On autoroutes with 2 or more traffic lanes in the direction travelled by the oversized vehicle, the latter must be escorted by a marked police emergency vehicle.*
- P-** *Must install, in accordance with Schedule 10 of this Regulation, at the rear of the oversized vehicle, a signal arrow light complying with section 180 of the Regulation respecting traffic control devices.*
- Q-** *Must travel with a rear escort vehicle, equipped with a signal arrow light complying with section 180 of the Regulation respecting traffic control devices and used in accordance with Schedule 11 of this Regulation.*
- R-** *Travel prohibited on a bridge where a sign prohibits travel by oversized vehicles.*
- 14-** *Must install an amber light complying with paragraph 1 of section 7 of this Regulation at the front end of the front overhang.*
- 15-** *Must allow other vehicles to pass every 15 minutes or at the first place where they can do so safely.*
- 16-** *When travelling, must keep a minimum distance of 30 kilometres from another oversized vehicle whose registration number is mentioned on the permit.*
- 17-** *Travel in convoy authorized for vehicles whose registration numbers are mentioned on the permit.*
- 18-** *Use of a conventional trailer or semi-trailer authorized.*

- S- Must use steel pontoons on bridges specified in the permit, in the presence of a representative of the ministère des Transports du Québec.*
- T- Travel authorized on all public highways.*
- U- Travel authorized on the network of autoroutes referred to in Schedule 4 of this Regulation.*
- 19- Must travel with an additional rear escort vehicle equipped with a signal arrow light complying with section 180 of the Regulation respecting traffic control devices and used in accordance with Schedule 12 of this Regulation.*
- 20- Must designate a person responsible for the convoy.*
- 21- Must travel with a spare tractor to be used in case of breakdown.*
- 22- Must install an amber light complying with paragraph 1 of section 7 of this Regulation at the rear end of the rear overhang.*
- 23- Must install, on both sides and in the middle of the load, lights complying with the third paragraph of paragraph 4 of section 7.*

SCHEDULE 4

(s. 2, 1st par., subpar. 6)

NETWORK OF AUTOROUTES

Autoroute 5

From the junction of route 148 (boul. Maisonneuve), exit 1 (Hull) to the junction of chemin de la Rivière, exit 21 (Chelsea).

Autoroute 10

From the junction of route 112, exit 115 (Magog) to the junction of route 112 (Fleurimont).

Autoroute 13

From the junction of autoroute 20 (Lachine) to the junction of autoroute 640, exit 22 (Boisbriand).

Autoroute 15

From the junction of autoroute 640, exit 21 (Saint-Eustache) to the junction of route 117 (Sainte-Agathe-des-Monts).

Autoroute 19

From the junction of boulevard Henri-Bourassa (Montréal) to the junction of boulevard Dagenais (Laval).

Autoroute 20

- (1) *From the southern approaches to the Louis-H.-Lafontaine bridge-tunnel, exit 90 (Longueuil) to the junction of autoroute 30, exit 98 (Boucherville).*
- (2) *From the junction of autoroute 55, exit 173 (Grantham) to the junction of boulevard Foucault, exit 181 (Saint-Charles de Drummond).*
- (3) *From exit 436 (Sainte-Anne-de-la-Pocatière) to the junction of the airport hill, exit 496 (Notre-Dame-du-Portage).*

Autoroute 25

From the southern approaches to the Louis-H.-Lafontaine bridge-tunnel, exit 90 (Longueuil) to the junction of autoroute 40, exit 4 (Anjou).

Autoroute 30

- (1) *From the junction of autoroute 10 (Brossard) to the junction of route 133, exit 186 (Sorel).*
- (2) *From the junction of route 132 (west of Bécancour) to the junction of route 132 (west of rivière Gentilly).*

Autoroute 40

From the junction of boulevard Saint-Pierre, exit 41 (Saint-Anne-de-Bellevue) to the junction of route 138 (Beauport).

Autoroute 50

From the junction of rue Montcalm (Hull) to the junction of route 309 (Masson).

Autoroute 55

- (1) *From the junction of route 112, exit 33 (Omerville) to the junction of autoroute 20 (Grantham).*
- (2) *From the junction of autoroute 30, exit 176 (Bécancour) to the junction of route 155 (Grand-Mère).*

Autoroute 73

From the junction of route 276 (Saint-Joseph-de-Beauce) to the junction of route 175 (Stoneham).

Autoroute 440

- (1) *From the junction of autoroute 13 (Laval) to the junction of autoroute 19, exit 27 (Laval).*
- (2) *From the junction of autoroute 40 (Sainte-Foy) to the junction of avenue Saint-Sacrement (Québec).*
- (3) *From the junction of côte d'Abraham (Québec) to the junction of autoroute 40, exit 29 (Beauport).*

Autoroute 540

From the interchange of the Pierre-Laporte bridge (Sainte-Foy) to the junction of route 138 (Sainte-Foy).

Autoroute 573

From the junction of autoroute 40 (Québec) to the junction of route 369 (Saint-Gabriel-de-Valcartier).

Autoroute 640

From the junction of the 25^e Avenue, exit 14 (Saint-Eustache) to the junction of route 344, exit 53 (Charlemagne).

SCHEDULE 5
(section 13)

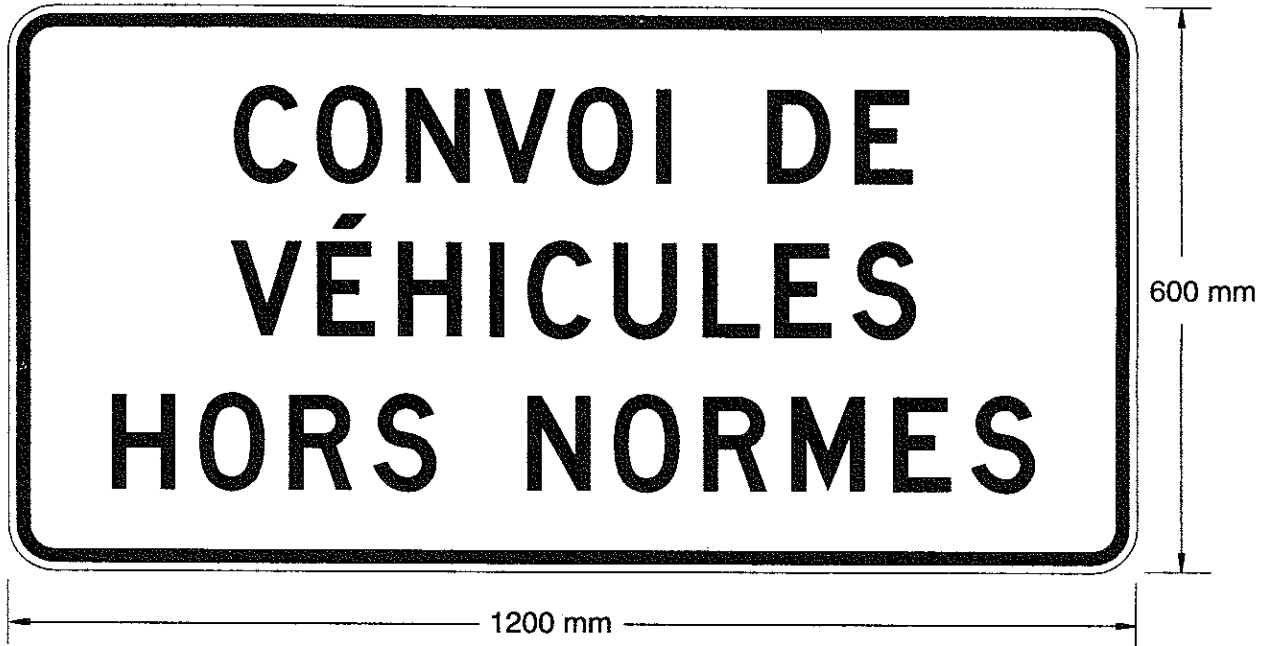

Board or hard surface

Text:

Highway gothic, "D" series, 102 mm, reflectorized red

Border:

15 mm, reflectorized red

Coating:

White, in compliance with Grade 2 of BNQ Standard 6830-101

SCHEDULE 6
(Schedule 3, condition k)



Board or hard surface

Text:

Highway gothic, "C" series, 127 mm, black

Border:

18 mm, black

Coating:

White, in compliance with Grade 2 of BNQ Standard 6830-101

SCHEDULE 7

(Schedule 3, conditions K, L, M or N)

SIGNALLING FOR AN OUTSIZED VEHICLE ON A BRIDGE WITH ONLY ONE TRAFFIC LANE IN THE DIRECTION TRAVELLED BY THE VEHICLE WHERE AN INTERRUPTION OF TRAFFIC IS REQUIRED TO ENABLE IT TO CROSS THE BRIDGE SLOWLY, ALONE AND IN THE EXACT CENTRE OF THE BRIDGE

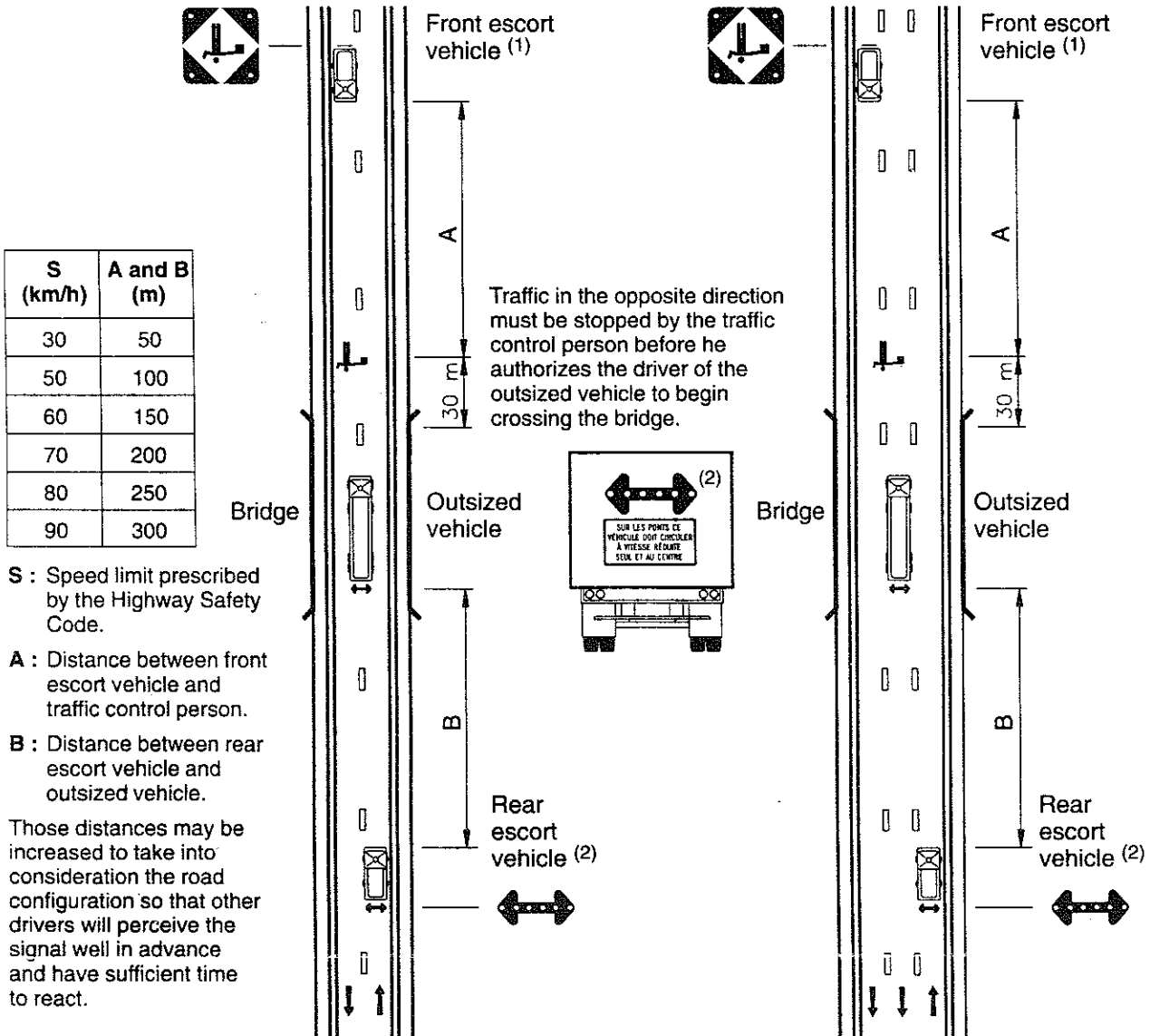

1. The "traffic control person ahead" sign must be used only to stop traffic. In such case, the flashing lights of that sign must be in operation. Otherwise, the sign must be turned down or hidden.
2. If condition "N" appears on the permit, a rear escort vehicle is required and the arrow must be installed on that vehicle. If condition "M" appears on the permit, the arrow must be installed on the oversized vehicle.
 The arrow must be flashing when the oversized vehicle is preparing to slow down at the approach to the bridge and while it is crossing the bridge; otherwise it must be turned off.

SCHEDULE 8

(Schedule 3, conditions K, L, M or N)

**SIGNALLING FOR AN OUTSIZED VEHICLE ON A BRIDGE WITH ONLY ONE TRAFFIC LANE
IN THE DIRECTION TRAVELLED BY THE VEHICLE WHERE AN INTERRUPTION
OF TRAFFIC IS NOT REQUIRED TO ENABLE IT TO CROSS THE BRIDGE SLOWLY,
ALONE AND IN THE EXACT CENTRE OF THE BRIDGE**

A : Distance between front escort vehicle and oversized vehicle. That distance must be between 100 m and 300 m and may be increased if the field of vision or visibility is reduced.

S (km/h)	B (m)
30	50
50	100
60	150
70	200
80	250
90	300

S : Speed limit prescribed by the Highway Safety Code.

B : Distance between rear escort vehicle and oversized vehicle. That distances may be increased to take into consideration the road configuration so that other drivers will perceive the signal well in advance and have sufficient time to react.

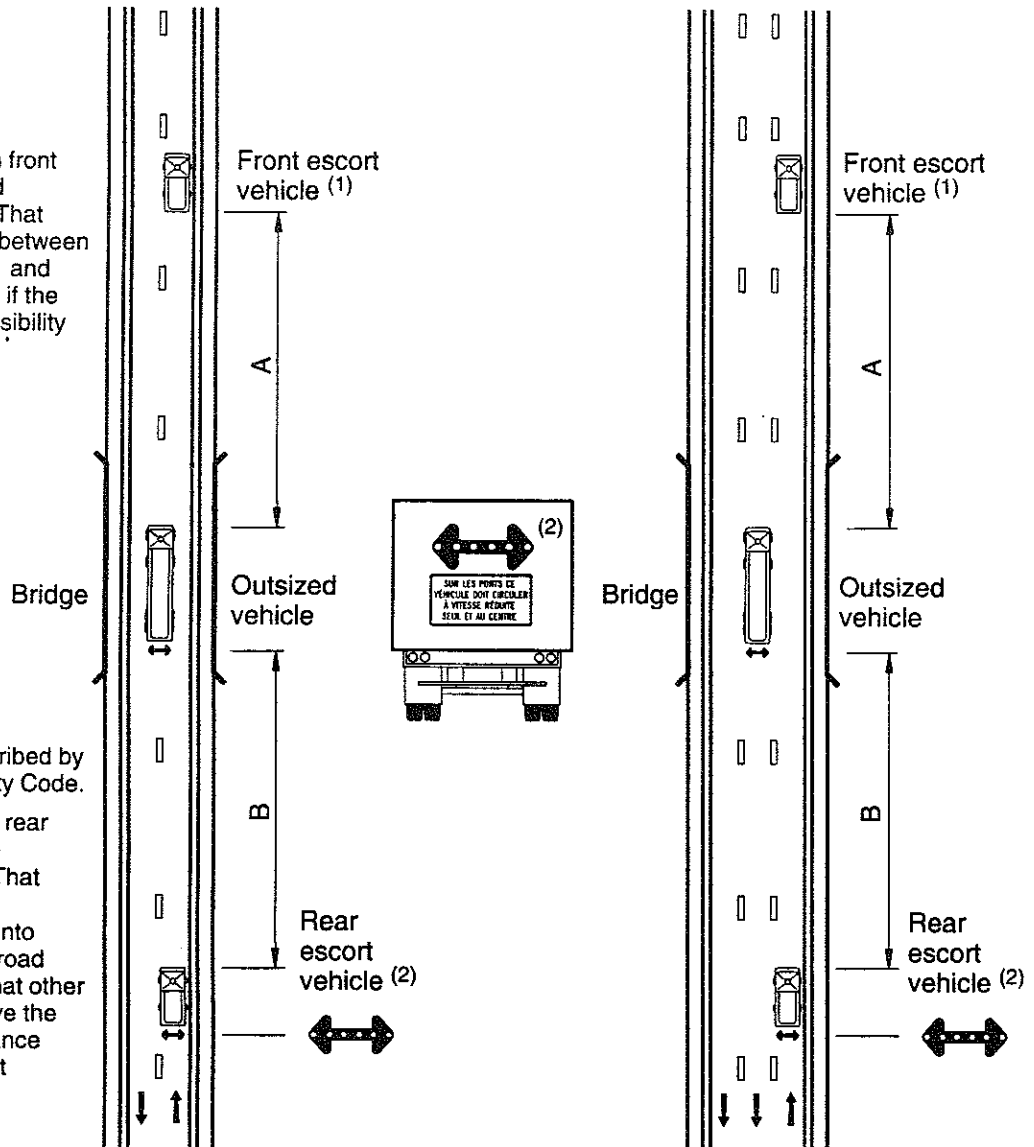

1. The "traffic control person ahead" sign must be turned down or hidden.
2. If condition "N" appears on the permit, a rear escort vehicle is required and the arrow must be installed on that vehicle. If condition "M" appears on the permit, the arrow must be installed on the oversized vehicle.

The arrow must be flashing when the oversized vehicle is preparing to slow down at the approach to the bridge and while it is crossing the bridge; otherwise it must be turned off.

SCHEDULE 9
(Schedule 3, conditions K and O)

SIGNALLING FOR AN OUTSIZED VEHICLE ON A BRIDGE WITH 2 OR MORE TRAFFIC LANES IN THE DIRECTION TRAVELLED BY THE VEHICLE TO ENABLE IT TO CROSS THE BRIDGE SLOWLY AND ALONE BY STRADDLING BOTH LANES OR, WHERE APPLICABLE, ALONE ON 2 LANES BY STRADDLING THE 2 FAR RIGHT LANES

S (km/h)	B (m)
30	50
50	100
60	150
70	200
80	250
90	300

S : Speed limit prescribed by the Highway Safety Code.

B : Distance between rear escort vehicles and oversized vehicle.⁽¹⁾

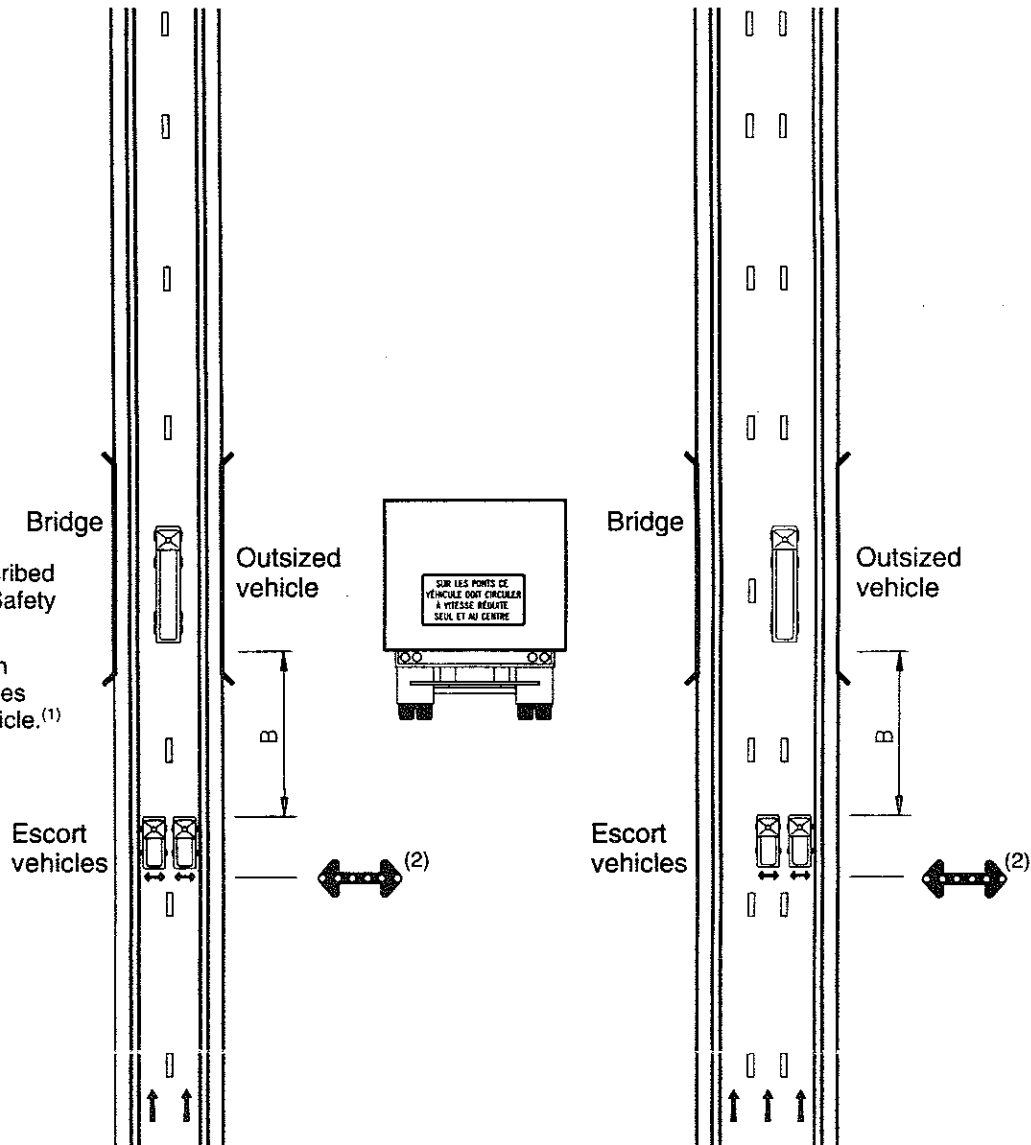

1. Where the oversized vehicle is preparing to slow down at the approach to a bridge, both escort vehicles must travel side by side at distance B from the oversized vehicle. They must then maintain the cruising speed they had before the approach to the bridge. On the bridge, that speed may be reduced, if necessary, until the oversized vehicle preceding them has crossed the bridge. Distance B may be increased to take into consideration the road configuration so that other drivers will perceive the signal well in advance and have sufficient time to react.
2. Arrows must be flashing when the oversized vehicle is preparing to slow down at the approach to the bridge and while it is crossing the bridge; otherwise they must be turned off.

SCHEDULE 10

(Schedule 3, conditions K, O and P)

SIGNALLING FOR AN OUTSIZED VEHICLE ON A BRIDGE LOCATED ON AN AUTOROUTE WITH 2 OR MORE TRAFFIC LANES IN THE DIRECTION TRAVELLED BY THE VEHICLE TO ENABLE IT TO CROSS THE BRIDGE SLOWLY AND ALONE BY STRADDLING BOTH LANES OR, WHERE APPLICABLE, ALONE ON 2 LANES BY STRADDLING THE 2 FAR RIGHT LANES

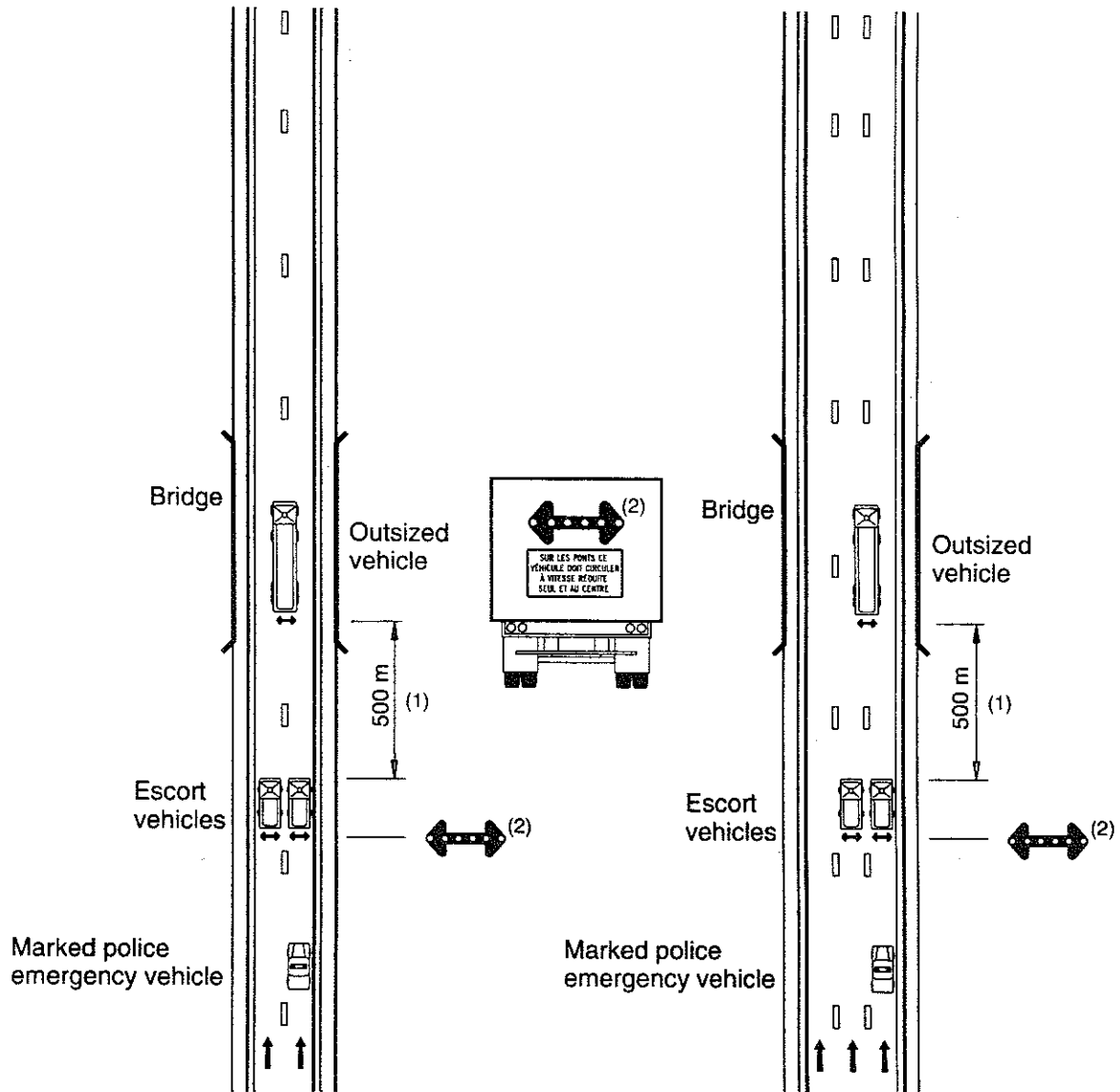

1. Where the oversized vehicle is preparing to slow down at the approach to a bridge, both escort vehicles must travel side by side and at a distance of 500 m from the oversized vehicle. They must then maintain the cruising speed they had before the approach to the bridge. On the bridge, that speed may be reduced, if necessary, until the oversized vehicle preceding them has crossed the bridge.
2. Arrows must be flashing when the oversized vehicle is preparing to slow down at the approach to the bridge and while it is crossing the bridge; otherwise they must be turned off.

SCHEDULE 11
(Schedule 3, condition Q)

SIGNALLING FOR AN OUTSIZED VEHICLE ON A BRIDGE LOCATED ON AN AUTOROUTE WITH 2 OR MORE TRAFFIC LANES IN THE DIRECTION TRAVELLED BY THE VEHICLE TO ENABLE IT TO CROSS THE BRIDGE SLOWLY

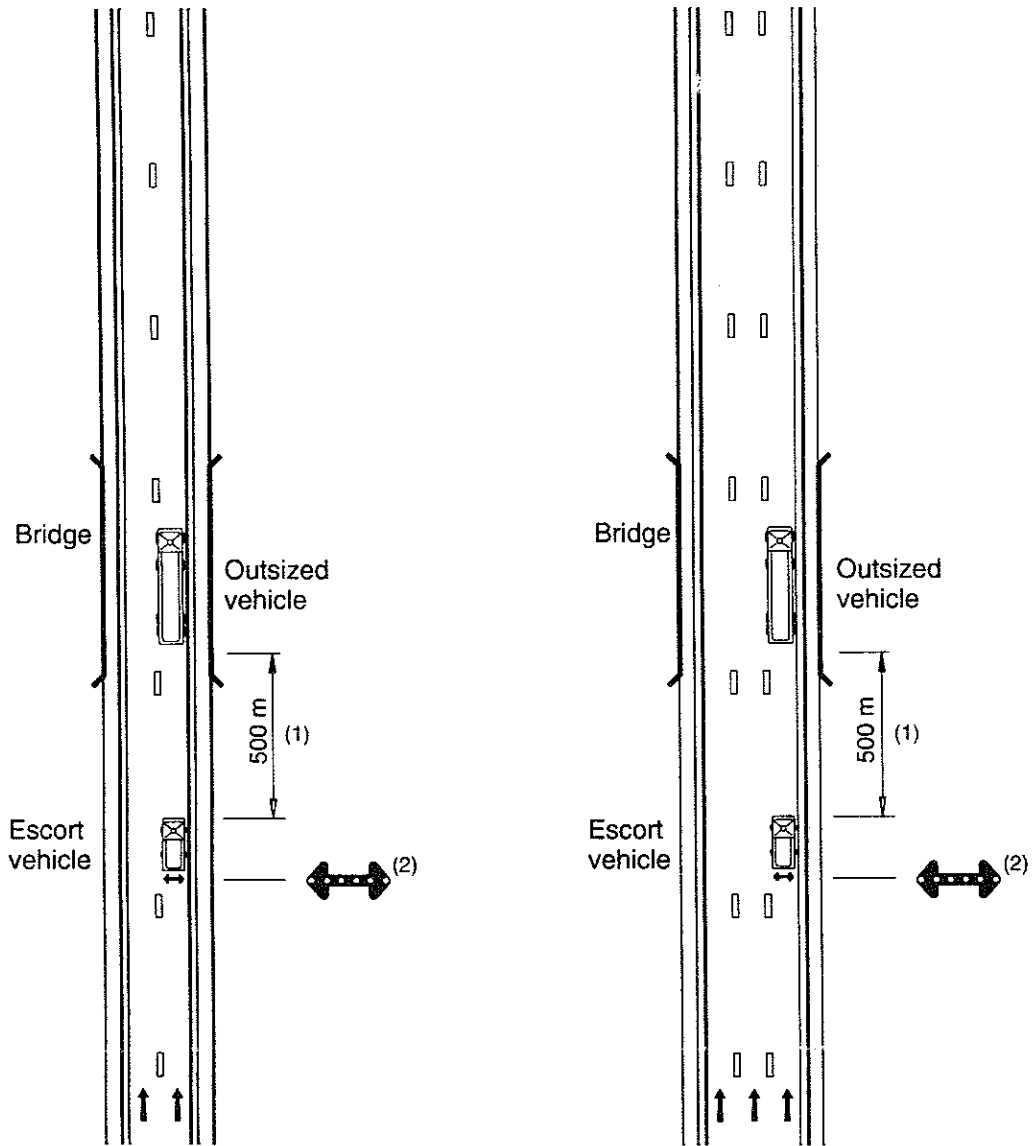

1. Where the oversized vehicle is preparing to slow down at the approach to a bridge, the escort vehicle must be 500 m from the oversized vehicle. It must then maintain the cruising speed it had before the approach to the bridge. On the bridge, that speed may be reduced, if necessary, until the oversized vehicle preceding them has crossed the bridge.
2. The arrow must be flashing when the oversized vehicle is preparing to slow down at the approach to the bridge and while it is crossing the bridge; otherwise it must be turned off.

SCHEDULE 12
(Schedule 3, conditions 8 and 19)

**METHOD FOR USING SIGNAL ARROW LIGHTS ON FRONT AND REAR
ESCORT VEHICLES ON A ROAD WITH ONLY ONE TRAFFIC LANE
IN THE DIRECTION TRAVELLED BY THE OUTSIZED VEHICLE**

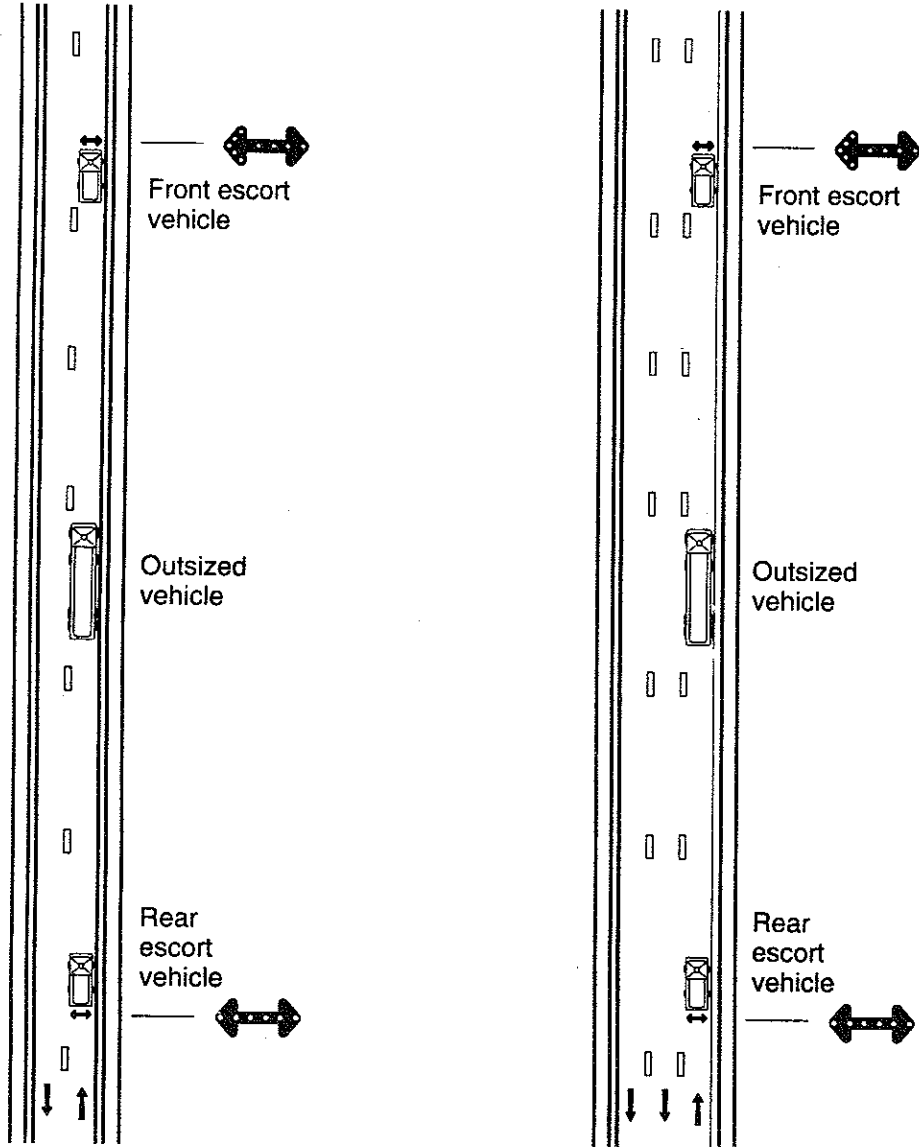

**METHOD FOR USING SIGNAL ARROW LIGHTS ON A REAR
ESCORT VEHICLE ON A ROAD WITH 2 OR MORE TRAFFIC LANES
IN THE DIRECTION TRAVELLED BY THE OUTSIZED VEHICLE**

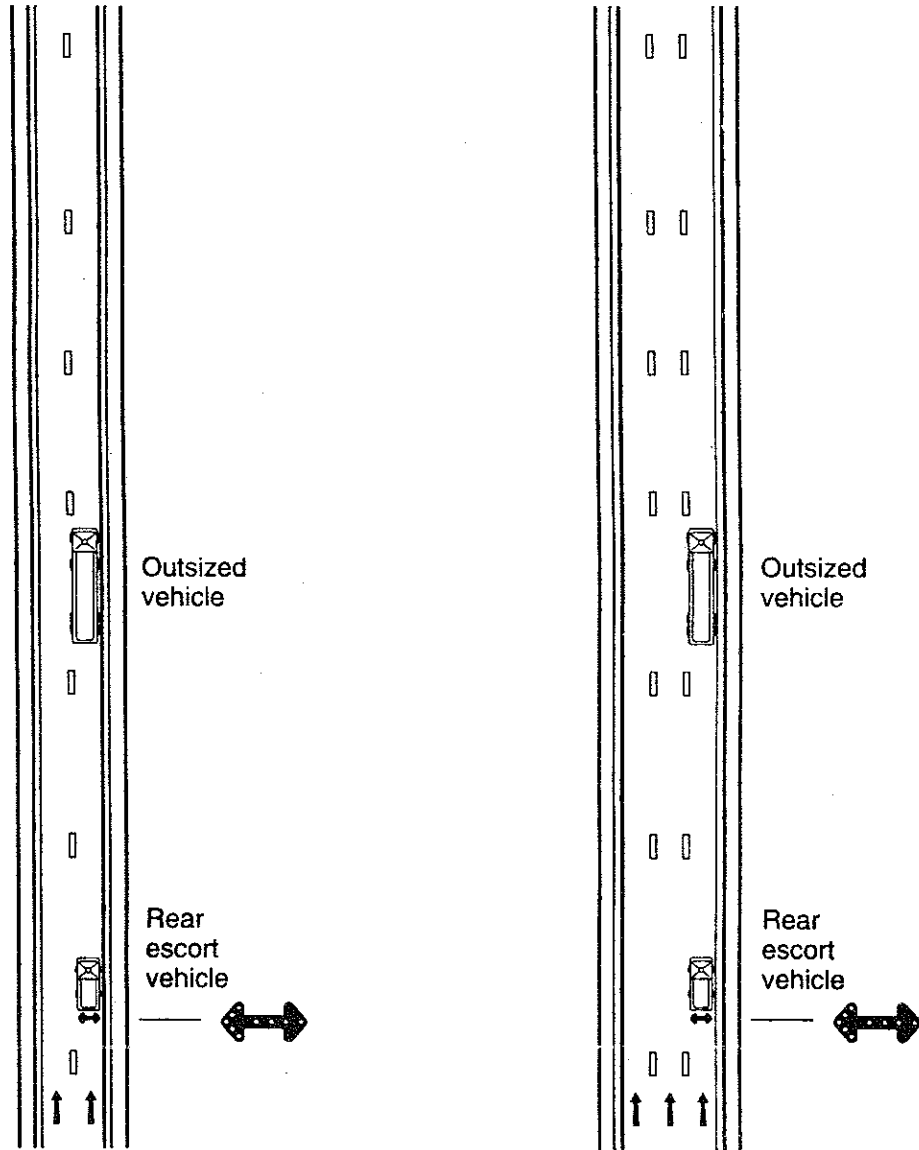

The present document has been prepared by the Direction du transport multimodal of the ministère des Transports du Québec.

Should you wish to obtain further information or forward your comments, please write to:

Direction des communications
Ministère des Transports du Québec
700, boul. René-Lévesque Est, 18^e étage
Québec (Québec) G1R 5H1

or communicate with:

Renseignements Transports
at the following numbers:

Montréal 514-873-2605
Québec 418-643-6864

7-11-2021 10:30 AM



